



ESM-4430 48 x 48 1/16 DIN Universal Input PID Process Controller

- 4 digits process (PV) and 4 digits process set (SV) display
- Universal process input (TC, RTD, mV $\overline{\text{---}}$, V $\overline{\text{---}}$, mA $\overline{\text{---}}$)
- Dual or multi point calibration for $\overline{\text{---}}$ Voltage / Current input
- Configurable ON/OFF, P, PI, PD and PID control forms
- Adaptation of PID coefficients to the system with Auto-tune and Self-tune
- Manual/Automatic mode selection for control outputs
- Bumpless transfer
- Programmable heating, cooling and alarm functions for control outputs

ABOUT INSTRUCTION MANUAL

Instruction manual of ESM-4430 Process Controller consists of two main sections. Explanation of these sections are below. Also, there are other sections which include order information and technical specifications of the device. All titles and page numbers in instruction manual are in “**CONTENTS**” section. User can reach to any title with section number.

Installation:

Physical dimensions, panel mounting, electrical wiring of the device, physical and electrical installation of the device to the system are explained in this section.

Operation and Parameters:

User interface of the device, how to access to the parameters, description of parameters are explained in this section.

Also in these sections, there are warnings to prevent serious injury while doing the physical and electrical mounting or using the device.

Explanation of the symbols which are used in these sections are given below.



This symbol is used for safety warnings. User must pay attention to these warnings.



This symbol is used to determine the dangerous situations as a result of an electric shock. User must pay attention to these warnings definitely.



This symbol is used to determine the important notes about functions and usage of the device

CONTENTS

1.PREFACE.....	Page	5
1.1 GENERAL SPECIFICATIONS		
1.2 ORDERING INFORMATION		
1.3 WARRANTY		
1.4 MAINTENANCE		
2.INSTALLATION.....	Page	8
2.1 GENERAL DESCRIPTION		
2.2 DIMENSIONS		
2.3 PANEL CUT-OUT		
2.4 ENVIRONMENTAL RATINGS		
2.5 PANEL MOUNTING		
2.6 INSTALLATION MOUNTING CLAMP		
2.7 REMOVING FROM THE PANEL		
3.ELECTRICAL WIRINGS.....	Page	13
3.1 TERMINAL LAYOUT AND CONNECTION INSTRUCTION		
3.2 ELECTRICAL WIRING DIAGRAM		
3.3 VIEW OF THE LABELS		
3.4 CONNECTION OF DEVICE SUPPLY VOLTAGE INPUT		
3.5 PROCESS INPUT CONNECTION		
3.5.1 TC (THERMOCOUPLE) CONNECTION		
3.5.2 RTD CONNECTION		
3.5.3 PROCESS INPUT CONNECTION OF SERIAL TRANSMITTERS WITH CURRENT OUTPUT (LOOP POWERED)		
3.5.4 PROCESS INPUT CONNECTION OF 3-WIRE TRANSMITTERS WITH CURRENT OUTPUT		
3.5.5 CONNECTION OF TRANSMITTERS WITH VOLTAGE OUTPUT TO PROCESS INPUT		
3.6 GALVANIC ISOLATION TEST VALUES OF ESM-4430 PROCESS CONTROLLER		
4.OUTPUT CONNECTION FORMS IN ESM-4430 PROCESS CONTROLLER.....	Page	21
4.1 PROCESS OUTPUT (SSR DRIVER OUTPUT) CONNECTION		
4.2 ALARM OUTPUT -1 RELAY CONNECTION		
4.3 PROCESS OUTPUT OR ALARM OUTPUT -2 RELAY CONNECTION		
5.DEFINITION OF FRONT PANEL AND ACCESSING TO THE PARAMETERS.....	Page	23
5.1 DEFINITION OF FRONT PANEL		
5.2 OBSERVATION OF SOFTWARE REVISION ON THE BOTTOM DISPLAY WHEN POWER IS ON		
5.3 ADJUSTMENT OF PROCESS AND ALARM SET VALUES		
5.4 EASY ACCESS DIAGRAM FOR PROGRAM PARAMETERS		
5.5 ACCESSING TO THE TECHNICIAN MENU		
5.6 CHANGING AND SAVING PARAMETERS		
6.PARAMETERS.....	Page	41
6.1 PROCESS / ALARM SET PARAMETERS		
6.2 TECHNICIAN PARAMETERS		
6.2.1 SELECTION OF PID TUNE AND OPERATION FORM		
6.2.2 FUNCTION SELECTION FOR TOP AND BOTTOM DISPLAY		
6.2.3 PROCESS INPUT TYPE AND RELEVANT PARAMETERS WITH PROCESS INPUT		
6.2.4 PID CONFIGURATION PARAMETERS		
6.2.5 PROCESS OUTPUT CONFIGURATION PARAMETERS		
6.2.6 ALARM OUTPUT - 1 CONFIGURATION PARAMETERS		
6.2.7 ALARM OUTPUT - 2 CONFIGURATION PARAMETERS		
6.2.8 GENERAL PARAMETERS		
6.2.9 TECHNICIAN PASSWORD		
7.FAILURE MESSAGES IN ESM-4430 PROCESS CONTROLLERS.....	Page	64
8.SPECIFICATIONS.....	Page	65
9.OTHER INFORMATION.....	Page	66

EU DECLARATION OF CONFORMITY

Manufacturer's Name : EMKO ELEKTRONIK A.S.
Manufacturer's Address : DOSAB, Karanfil Sk., No:6,
16369 Bursa, TURKEY

The manufacturer hereby declares that the product:

Product Name : Process Controller Unit
Type Number : ESM-4430
Product Category : Electrical equipment for measurement, control and laboratory use

Conforms to the following directives :

2006 / 95 / EC The Low Voltage Directive

2004 / 108 / EC The Electromagnetic Compatibility Directive

has been designed and manufactured to the following specifications :

EN 61000-6-4:2007 EMC Generic Emission Standard for the Industrial Environments

EN 61000-6-2:2005 EMC Generic Immunity Standard for the Industrial Environments

EN 61010-1:2001 Safety Requirements for electrical equipment for measurement, control And laboratory use

When and Where Issued

16th October 2009

Bursa-TURKEY

Authorized Signature

Name : Serpil YAKIN

Position : Quality Manager

1.Preface

ESM series process controllers are designed for measuring and controlling temperature and any process value. They can be used in many applications with their universal process input, control outputs, selectable alarm functions.

Some application fields and applications which they are used are below:

<u>Application Fields</u>	<u>Applications</u>
Glass	PID Process Control
Plastic	
Petro-Chemistry	
Textile	
Automotive	
Machine production industries	

1.1 General Specifications

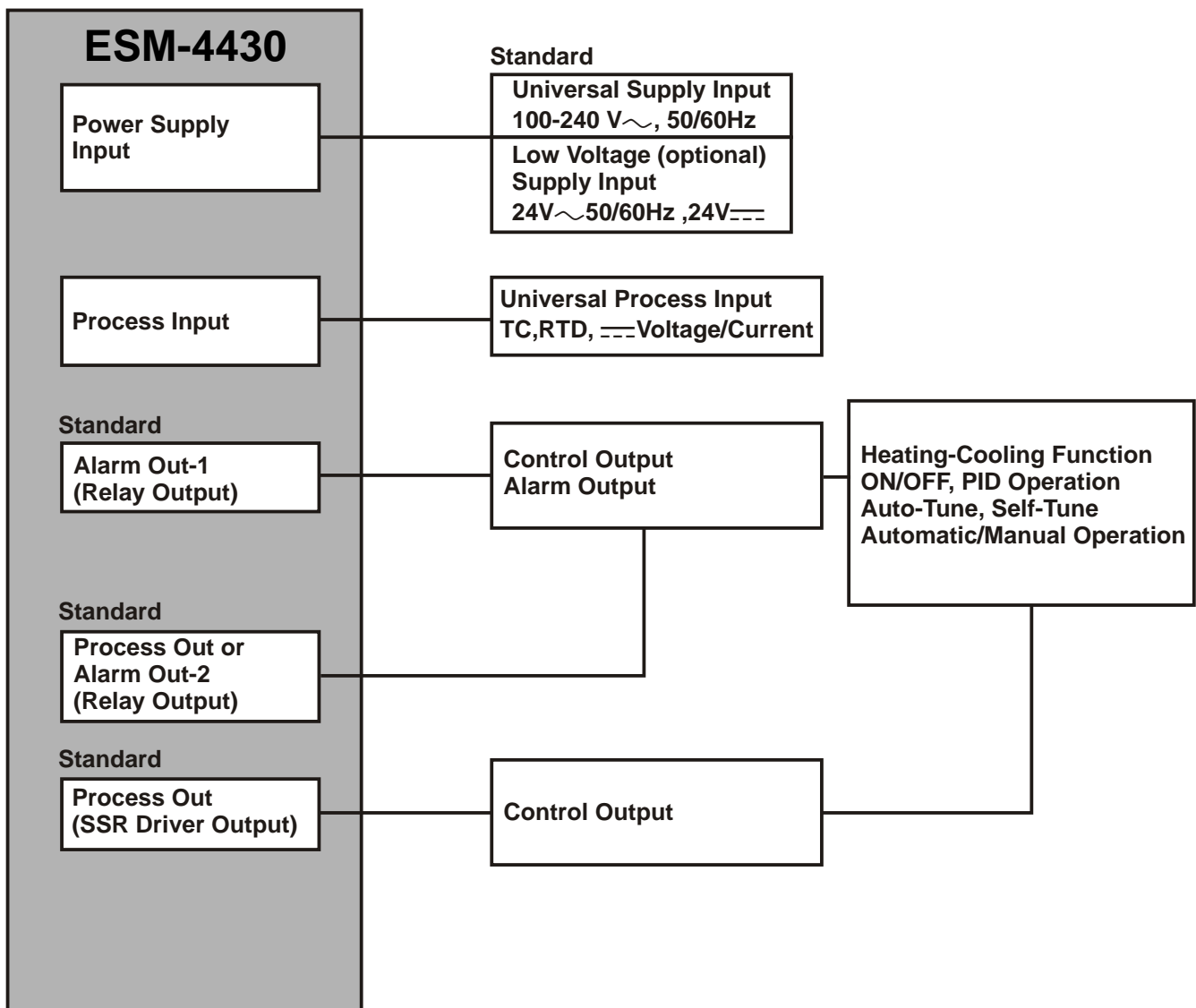

1.2 Ordering Information

ESM-4430 (48x48 DIN 1/16)	A	BC	D	E	/	FG	HI	/	U	V	W	Z
			0	1	/	01	02	/				

A	Supply Voltage
1	100-240V \sim (-15%;+10%) 50/60Hz
2	24 V \sim (-15%;+10%) 50/60Hz 24V \equiv (-15%;+10%)
9	Customer (Maximum 240V \sim (-15%;+10%))50/60Hz

BC	Input Type	Scale
20	Configurable (Table-1)	Table-1

D	Serial Communication
0	None

E	Output-1
1	Relay Output (5A@250 V \sim at resistive load)

FG	Output-2
01	Relay Output (5A@250 V \sim at resistive load)

HI	Output-3
02	SSR Driver Output (Maximum 17mA, 25V \equiv)

Table-1

BC	Input Type(TC)	Scale(°C)	Scale(°F)
21	L ,Fe Const DIN43710	-100°C,850°C	-148°F ,1562°F
22	L ,Fe Const DIN43710	-100.0°C,850.0°C	-148.0°F,999.9°F
23	J ,Fe CuNi IEC584.1(ITS90)	-200°C,900°C	-328°F,1652°F
24	J ,Fe CuNi IEC584.1(ITS90)	-199.9°C,900.0°C	-199.9°F,999.9°F
25	K ,NiCr Ni IEC584.1(ITS90)	-200°C,1300°C	-328°F,2372°F
26	K ,NiCr Ni IEC584.1(ITS90)	-199.9°C,999.9°C	-199.9°F,999.9°F
27	R ,Pt13%Rh Pt IEC584.1(ITS90)	0°C,1700°C	32°F,3092°F
28	S ,Pt10%Rh Pt IEC584.1(ITS90)	0°C,1700°C	32°F,3092°F
29	T ,Cu CuNi IEC584.1(ITS90)	-200°C,400°C	-328°F,752°F
30	T ,Cu CuNi IEC584.1(ITS90)	-199.9°C,400.0°C	-199.9°F,752.0°F
31	B ,Pt30%Rh Pt6%Rh IEC584.1(ITS90)	44°C,1800°C	111°F,3272°F
32	B ,Pt30%Rh Pt6%Rh IEC584.1(ITS90)	44.0°C,999.9°C	111.0°F,999.9°F
33	E ,NiCr CuNi IEC584.1(ITS90)	-150°C,700°C	-238°F,1292°F
34	E ,NiCr CuNi IEC584.1(ITS90)	-150.0°C,700.0°C	-199.9°F,999.9°F
35	N ,Nicrosil Nisil IEC584.1(ITS90)	-200°C,1300°C	-328°F,2372°F
36	N ,Nicrosil Nisil IEC584.1(ITS90)	-199.9°C,999.9°C	-199.9°F,999.9°F
37	C , (ITS90)	0°C,2300°C	32°F,3261°F
38	C , (ITS90)	0.0°C,999.9°C	32.0°F,999.9°F

BC	Input Type(RTD)	Scale(°C)	Scale(°F)
39	PT 100 , IEC751(ITS90)	-200°C,650°C	-328°F,1202°F
40	PT 100 , IEC751(ITS90)	-199.9°C,650.0°C	-199.9°F,999.9°F

BC	Input Type(\equiv Voltage and Current)	Scale
41	0...50 mV \equiv	-1999,9999
42	0...5 V \equiv	-1999,9999
43	0...10 V \equiv	-1999,9999
44	0...20 mA \equiv	-1999,9999
45	4...20 mA \equiv	-1999,9999

All order information of ESM-4430 are given on the table at left. User may form appropriate device configuration from information and codes that at the table and convert it to the ordering codes.

Firstly, supply voltage then other specifications must be determined. Please fill the order code blanks according to your needs.

Please contact us, if your needs are out of the standards.



\sim Symbol means Vac,

\equiv Symbol means Vdc

\sim Symbol means Vac and Vdc

1.3 Warranty

EMKO Elektronik warrants that the equipment delivered is free from defects in material and workmanship. This warranty is provided for a period of two years. The warranty period starts from the delivery date. This warranty is in force if duty and responsibilities which are determined in warranty document and instruction manual performs by the customer completely.

1.4 Maintenance

Repairs should only be performed by trained and specialized personnel. Cut power to the device before accessing internal parts.

Do not clean the case with hydrocarbon-based solvents (Petrol, Trichlorethylene etc.). Use of these solvents can reduce the mechanical reliability of the device. Use a cloth dampened in ethyl alcohol or water to clean the external plastic case.

2. Installation



Before beginning installation of this product, please read the instruction manual and warnings below carefully.

In package ,

- One piece unit
- Two pieces mounting clamps
- One piece instruction manual

A visual inspection of this product for possible damage occurred during shipment is recommended before installation. It is your responsibility to ensure that qualified mechanical and electrical technicians install this product.

If there is danger of serious accident resulting from a failure or defect in this unit, power off the system and separate the electrical connection of the device from the system.

The unit is normally supplied without a power switch or a fuse. Use power switch and fuse as required.

Be sure to use the rated power supply voltage to protect the unit against damage and to prevent failure.

Keep the power off until all of the wiring is completed so that electric shock and trouble with the unit can be prevented.

Never attempt to disassemble, modify or repair this unit. Tampering with the unit may results in malfunction, electric shock or fire.

Do not use the unit in combustible or explosive gaseous atmospheres.

During the equipment is putted in hole on the metal panel while mechanical installation some metal burrs can cause injury on hands, you must be careful.

Montage of the product on a system must be done with it's fixing clamps. Do not do the montage of the device with inappropriate fixing clamp. Be sure that device will not fall while doing the montage.

It is your responsibility if this equipment is used in a manner not specified in this instruction manual.

2.1 General Description

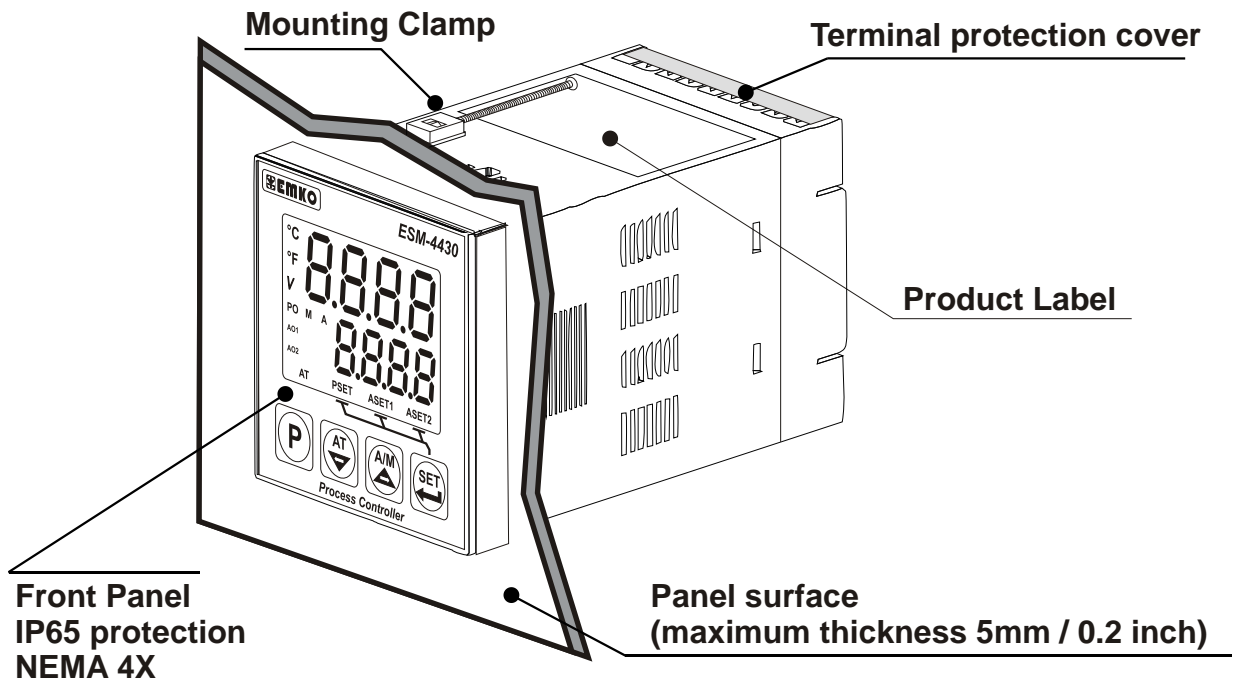

2.2 Dimensions

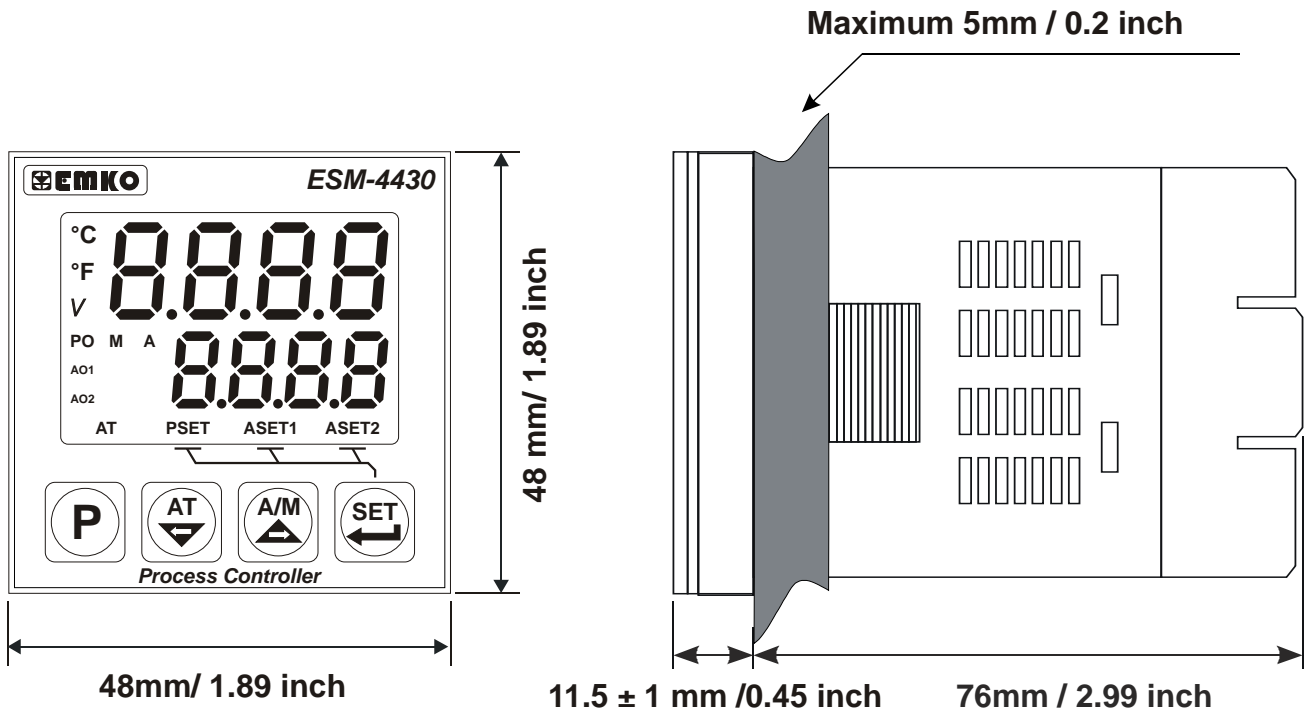

2.3 Panel Cut-Out

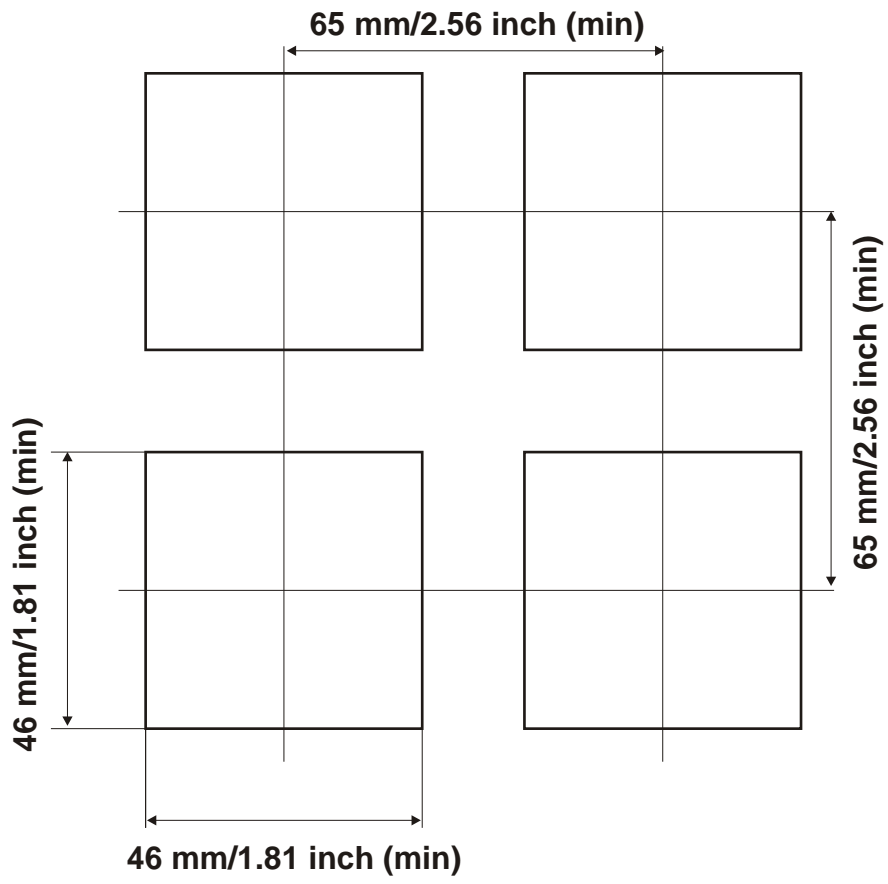

2.4 Environmental Ratings

Operating Conditions



Operating Temperature : 0 to 50 °C



Max. Operating Humidity : 90% Rh (non-condensing)



Altitude : Up to 2000m.



Forbidden Conditions:

Corrosive atmosphere

Explosive atmosphere

Home applications (The unit is only for industrial applications)

2.5 Panel Mounting

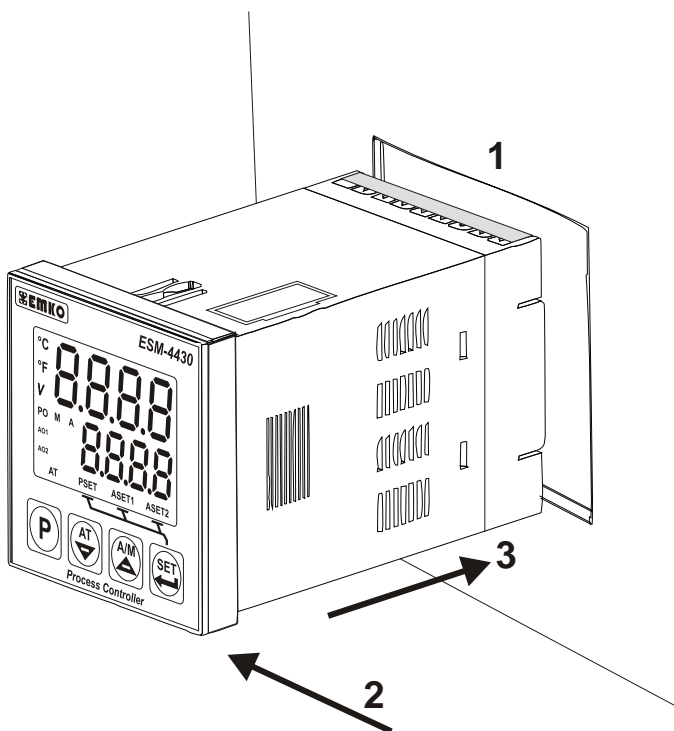

1-Before mounting the device in your panel, make sure that the cut-out is of the right size.

2-Check front panel gasket position

3-Insert the device through the cut-out. If the mounting clamp are on the unit, put out them before inserting the unit to the panel.



During installation into a metal panel, care should be taken to avoid injury from metal burrs which might be present. The equipment can loosen from vibration and become dislodged if installation parts are not properly tightened. These precautions for the safety of the person who does the panel mounting.

2.6 Installation Mounting Clamp

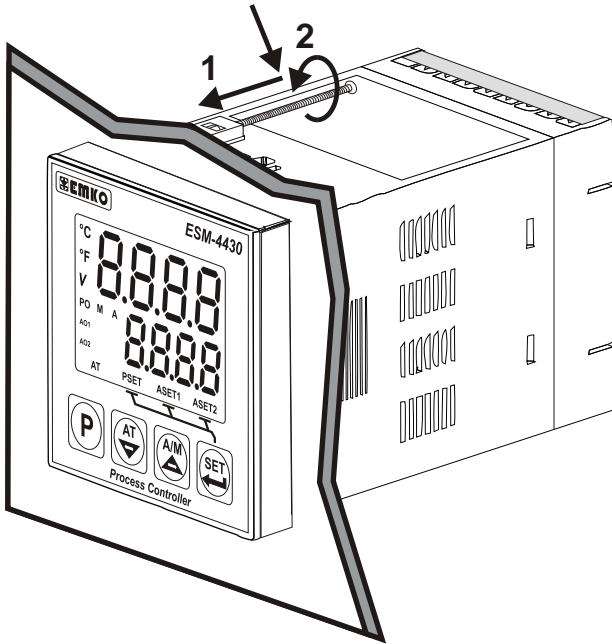

The unit is designed for panel mounting.

1-Insert the unit in the panel cut-out from the front side.

2- Insert the mounting clamps to the holes that located top and bottom sides of device and screw up the fixing screws until the unit completely immobile within the panel



Montage of the unit to a system must be done with it's own fixing clamps. Do not do the montage of the device with inappropriate fixing clamps. Be sure that device will not fall while doing the montage.

2.7 Removing from the Panel



Before starting to remove the unit from panel, power off the unit and the related system.

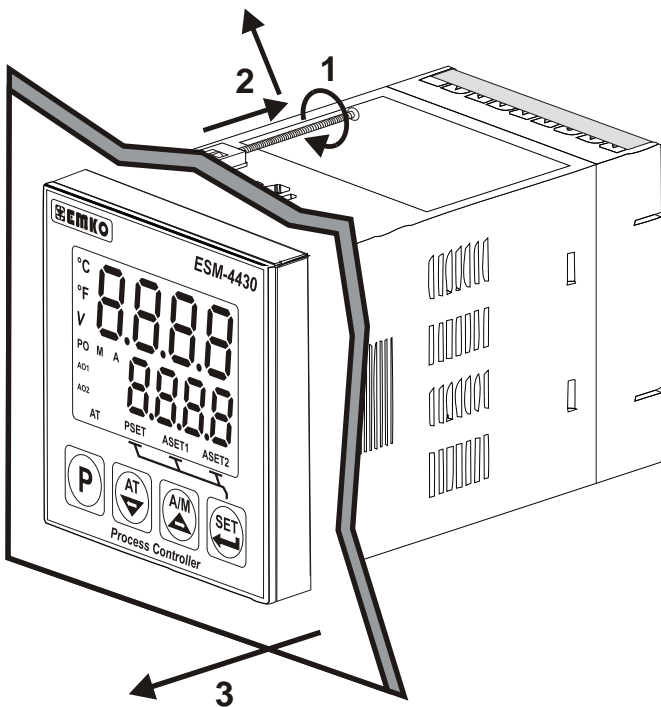

1-Loosen the screws.

2-Pull mounting clamps from top and bottom fixing sockets.

3-Pull the unit through the front side of the panel

3. Electrical Wirings



You must ensure that the device is correctly configured for your application. Incorrect configuration could result in damage to the process being controlled, and/or personal injury. It is your responsibility, as the installer, to ensure that the configuration is correct.

Parameters of the device has factory default values. These parameters must be set according to the system's needs.



Only qualified personnel and technicians should work on this equipment. This equipment contains internal circuits with voltage dangerous to human life. There is severe danger for human life in the case of unauthorized intervention.



Be sure to use the rated power supply voltage to protect the unit against damage and to prevent failure.



Keep the power off until all of the wiring is completed so that electric shock and trouble with the unit can be prevented.

3.1 Terminal Layout and Connection Instructions

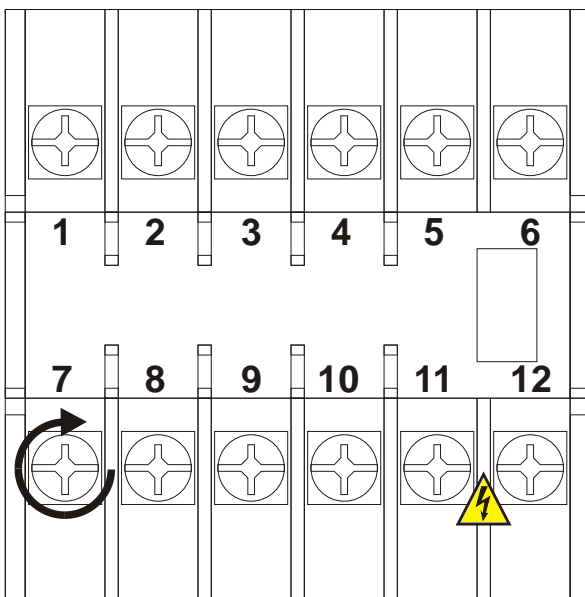

0.5 Nm

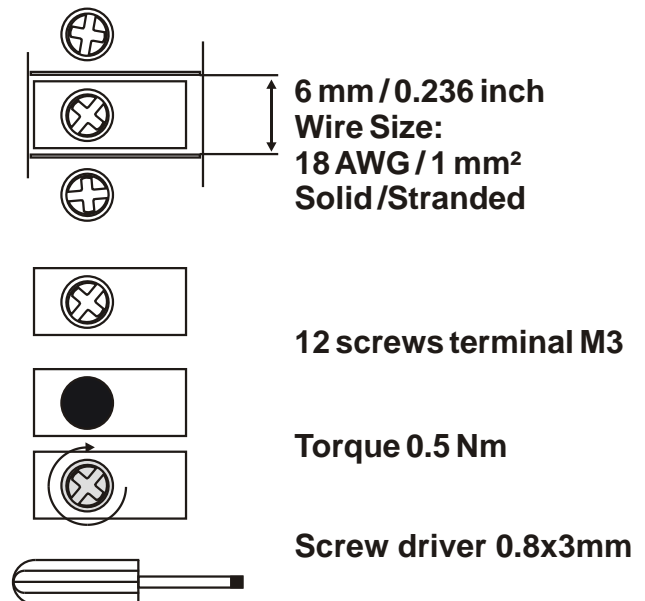

3.2 Electrical Wiring Diagram



Electrical wiring of the device must be the same as 'Electrical Wiring Diagram' below to prevent damage to the process being controlled and personnel injury.

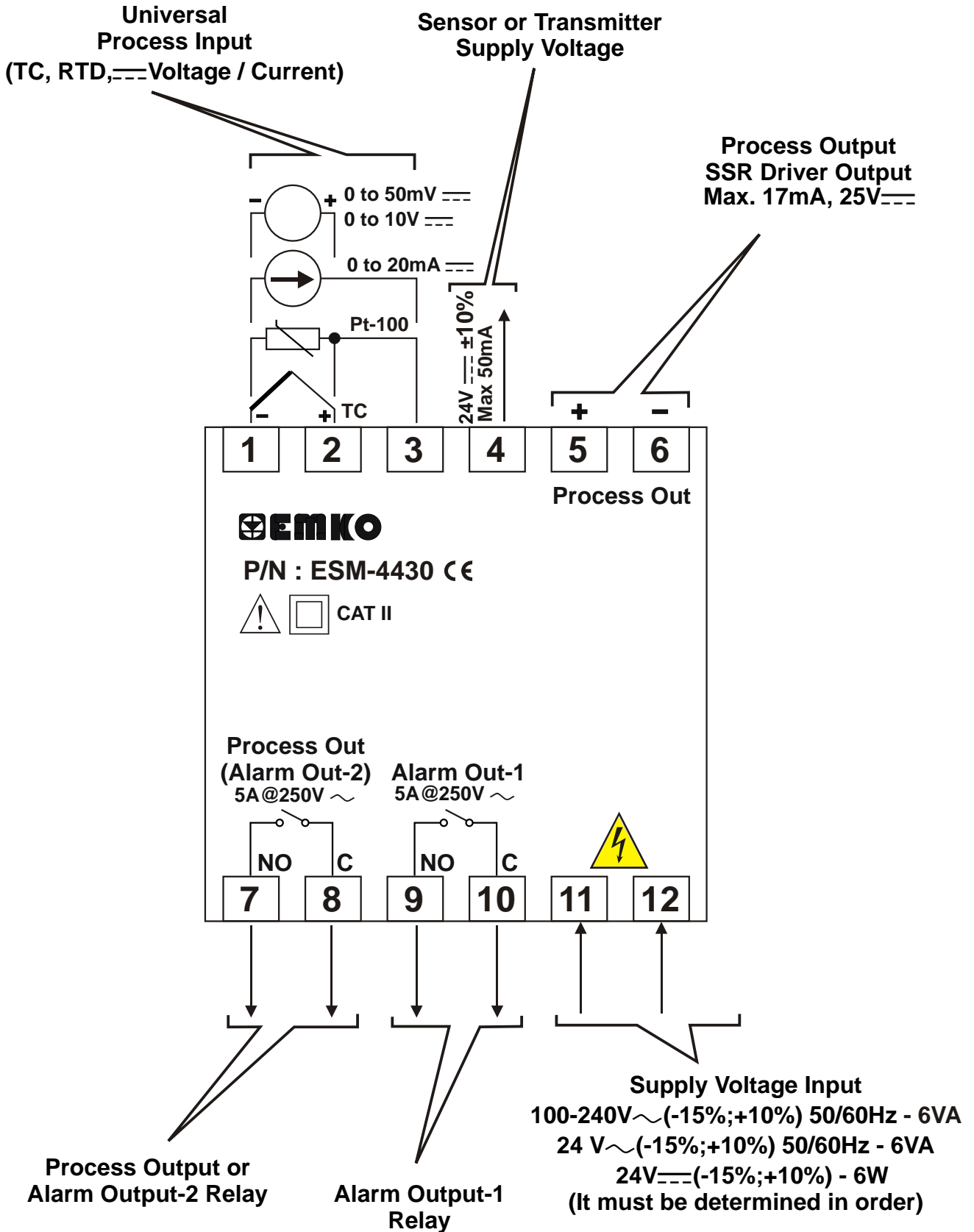

Process input is in CAT II class

3.3 View of the Labels

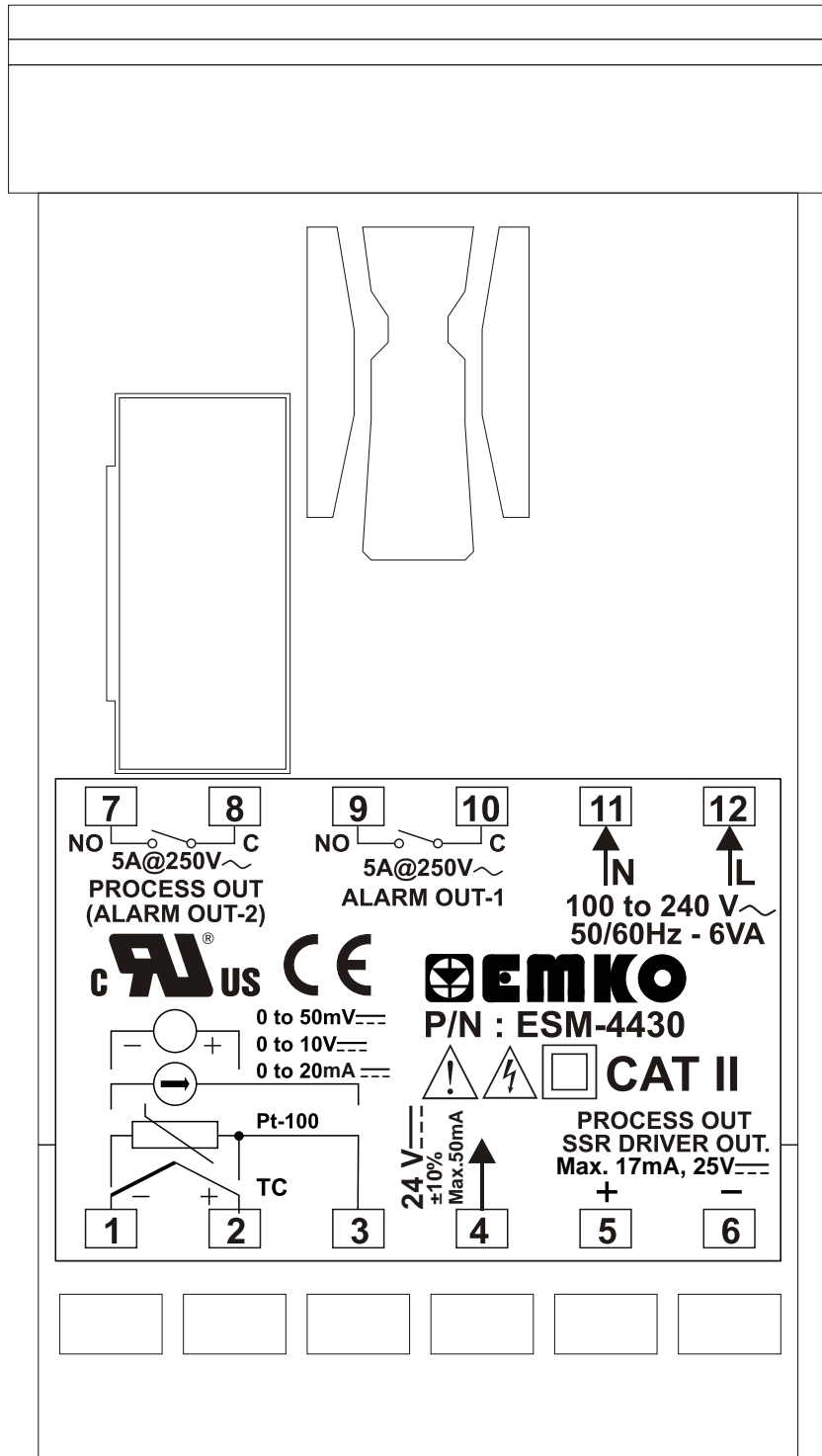

3.4 Connection of Device Supply Voltage Input

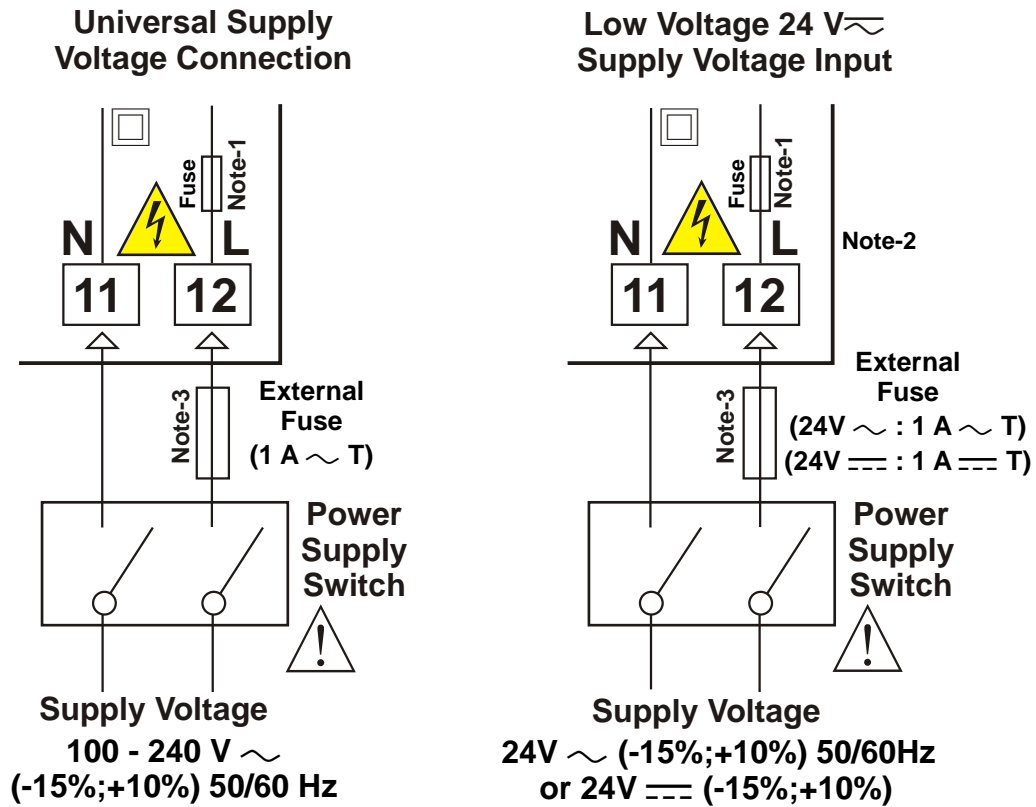

Note-1 : There is an internal 33R fusible flameproof resistor in 100-240 V \sim 50/60Hz supply voltage input

There is an internal 4R7 fusible flameproof resistor in 24V \sim 50/60Hz, 24V \equiv supply voltage input

Note-2 : "L" is (+), "N" is (-) for 24V \equiv supply voltage

Note-3 : External fuse is recommended.



Make sure that the power supply voltage is the same indicated on the instrument.

Switch on the power supply only after that all the electrical connections have been completed.

Supply voltage range must be determined in order. While installing the unit, supply voltage range must be controlled and appropriate supply voltage must be applied to the unit. Controlling prevents damages in unit and system and possible accidents as a result of incorrect supply voltage.



There is no power supply switch on the device. So a power supply switch must be added to the supply voltage input. In accordance with the safety regulations, the power supply switch shall bring the identification of the relevant instrument. Power supply switch shall be easily accessible by the user.

Power switch must be two poled for separating phase and neutral. On/Off condition of power switch is very important in electrical connection. On/Off condition of power switch must be signed for preventing the wrong connection.

If an external fuse is used, it must be on phase connection in \sim supply input.

If an external fuse is used, it must be on (+) line connection in \equiv supply input.



The instrument is protected with an internal fuse (Please refer to Note1 for information). In case of failure it is suggested to return the instrument to the manufacturer for repair.

3.5 Process Input Connection

3.5.1 TC (Thermocouple) Connection

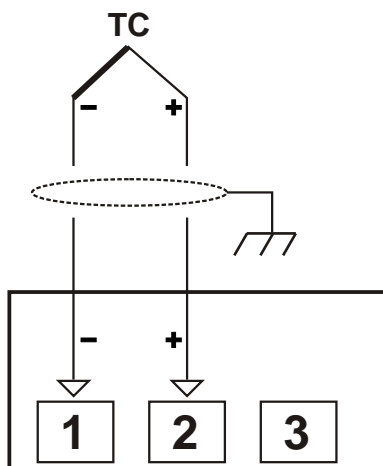

Connect the wires with the polarity as shown in the figure at left.



Always use compensation wire corresponding to the thermocouple used. If present, the shield must be connected to a proper ground.



Input resistance is greater than 10M

3.5.2 RTD Connection

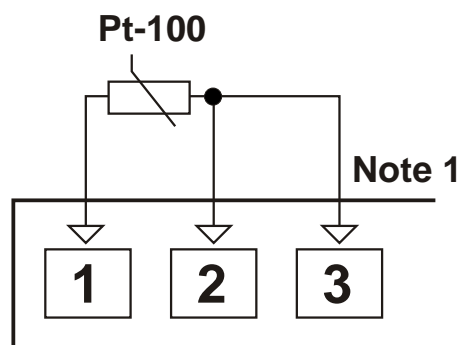

3-wire Pt-100 connection
(with line compensation)
(Max. Line impedance is 10 Ω)

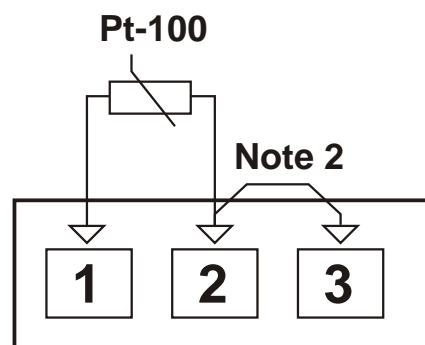

2-wire Pt-100 connection
(without line compensation)

Note 1 : In 3-wire system, use always cables of the same diameter (min 1mm²) Always use wires of the same gauge and type whether a 2-wire or 3-wire system.

Note 2 : Install a jumper between terminals 2 and 3 when using a 2-wire RTD.

Note 3 : If the distance is longer than 10 meters, use 3-wire system



Input resistance is greater than 10M

3.5.3 Process Input Connection of Serial Transmitters with Current Output (Loop Powered)

Transmitter connection by using supply voltage on the device

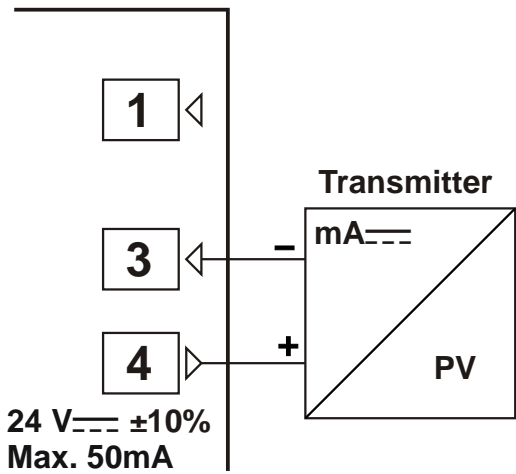

Transmitter connection by using external supply voltage source.

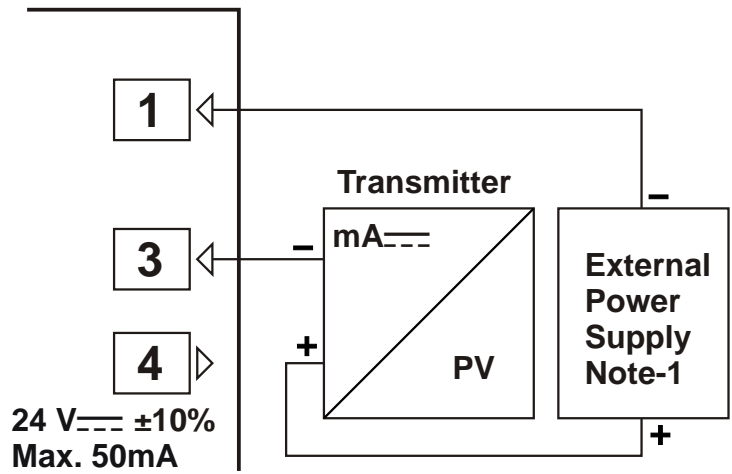

Note 1 : External power supply must be selected according to supply voltage range and required current for transmitter.

i Input resistance is 2R7 .

3.5.4 Process Input Connection of 3-wire Transmitters with Current Output

Transmitter connection by using supply voltage on the device

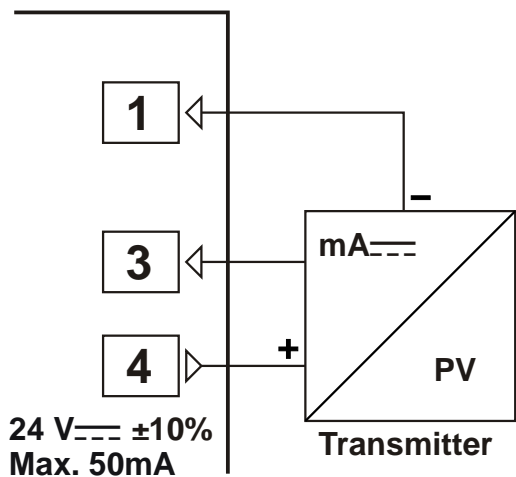

Transmitter connection by using external supply voltage source.

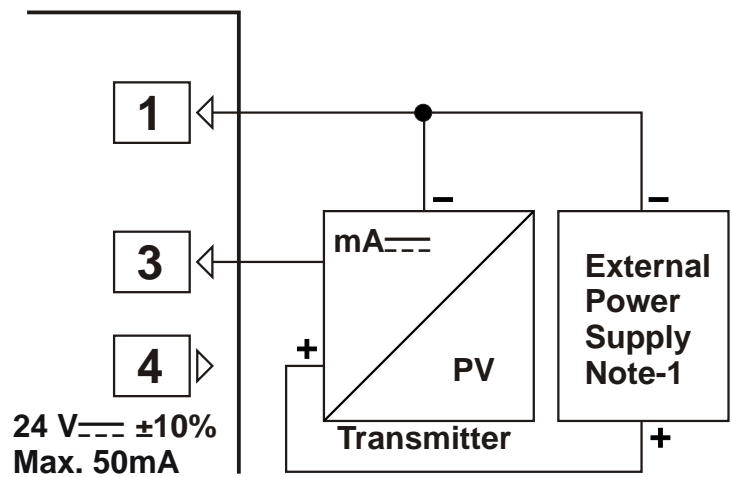

Note-1 : External power supply must be selected according to supply voltage range and required current for transmitter.

i Input resistance is 2R7 .

3.5.5 Connection of Transmitters with Voltage Output to Process Input

Transmitter connection by using supply voltage on the device

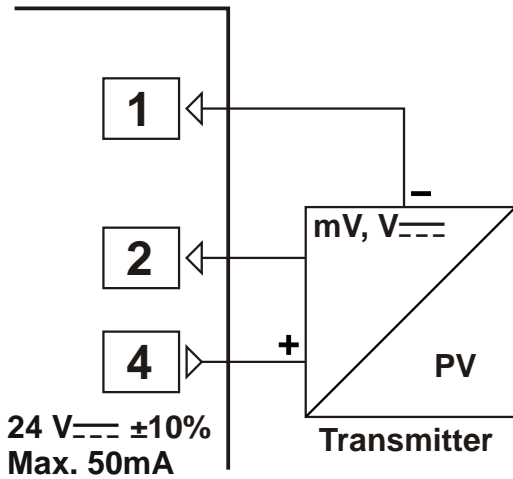

Transmitter connection by using external supply voltage source.

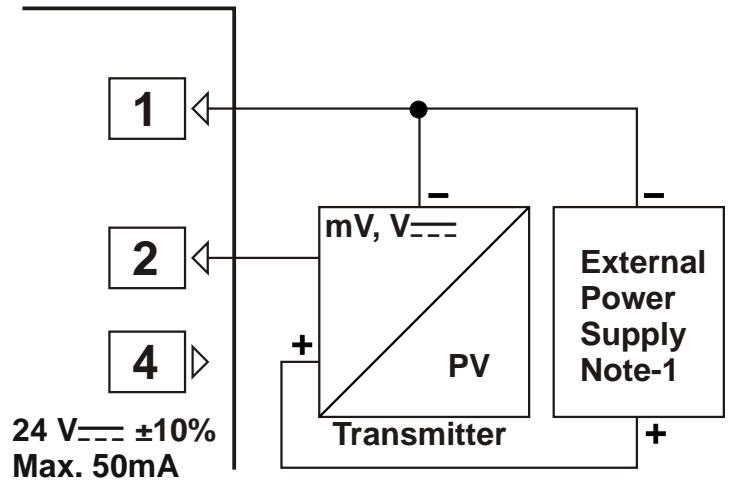

Note-1 : External power supply must be selected according to supply voltage range and required current for transmitter.



Input resistance is greater than 10M Ω for 0...50mV
Input resistance is greater than 43K Ω for 0...10V

3.6 Galvanic Isolation Test Values of ESM-4430 Process Controller

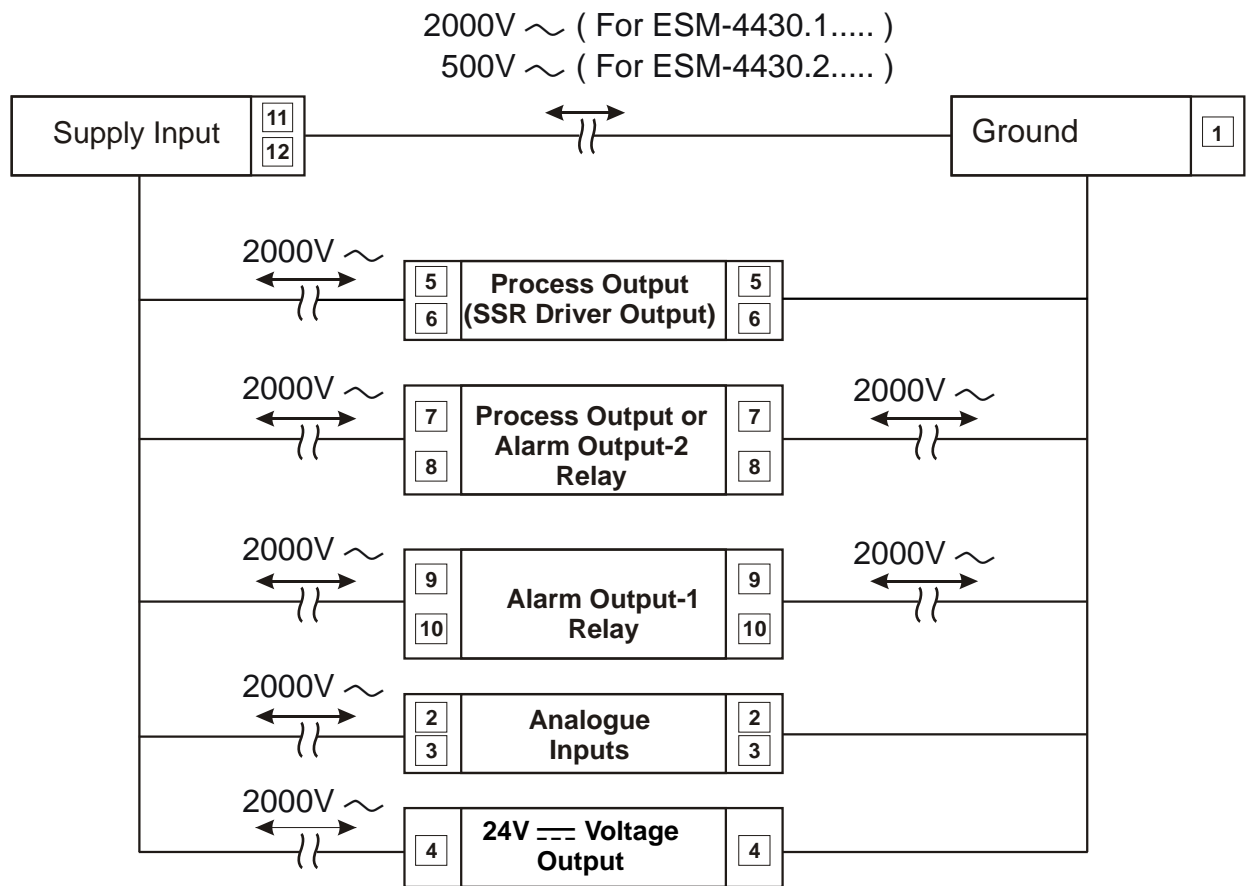

4. Output Connection Forms in ESM-4430 Process Controller

4.1 Process Output (SSR Driver Output) Connection

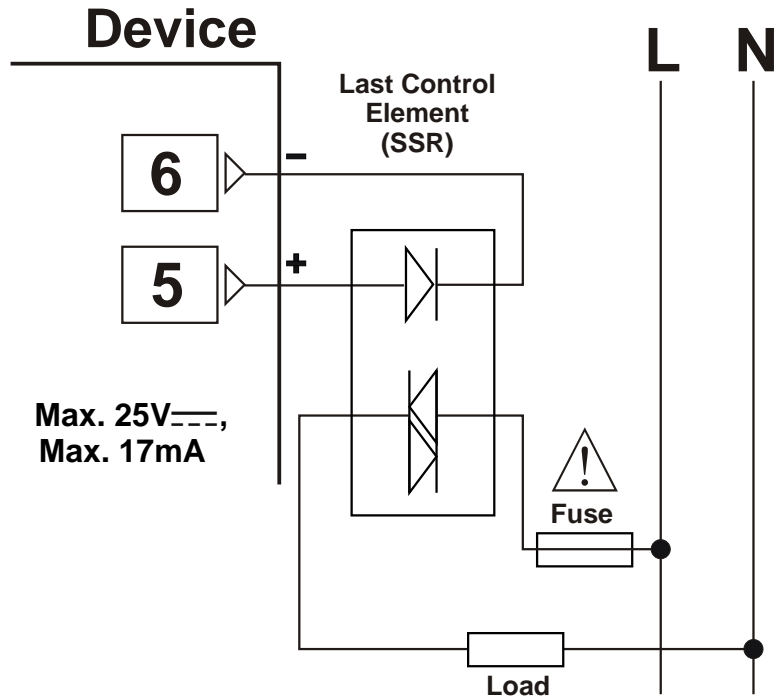

Fuses must be selected according to the applications.

4.2 Alarm Output-1 Relay Connection

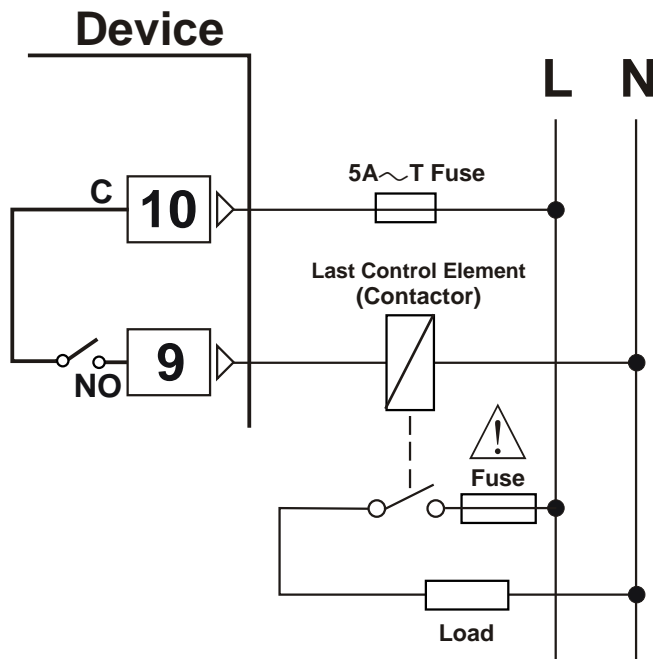

Fuses must be selected according to the applications.

4.3 Process Output or Alarm Output-2 Relay Connection

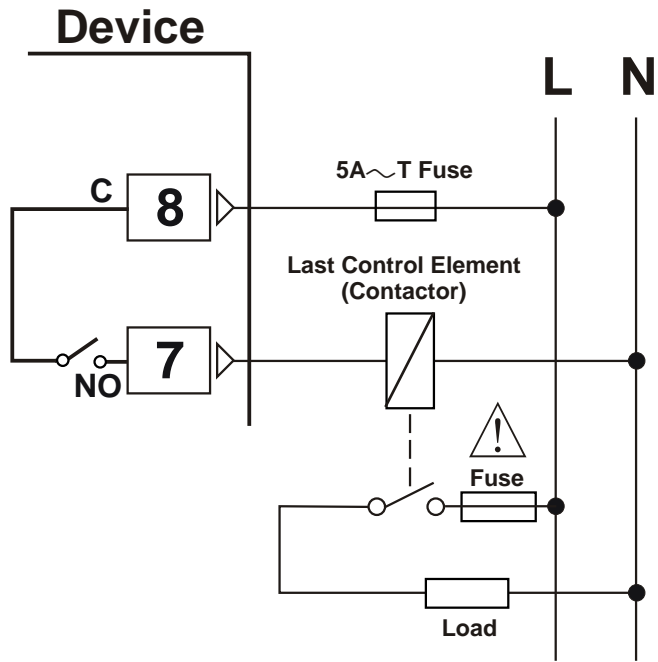

Fuses must be selected according to the applications.

5. Definition of Front Panel and Accessing to the Parameters

5.1 Definition of Front Panel

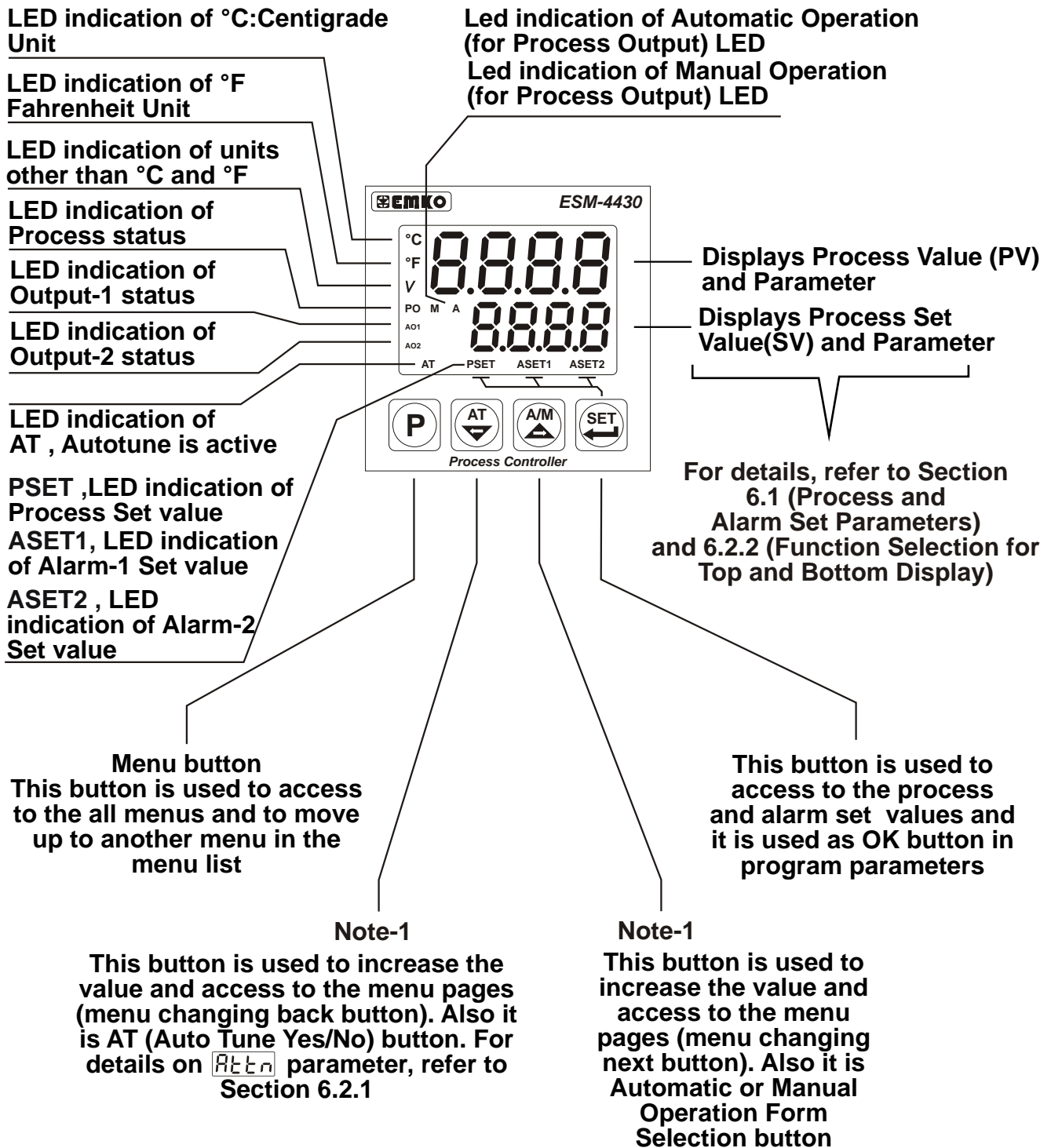

Note-1: If increment or decrement button is pressed for 5 seconds continuously, increment and decrement number become 10, if increment or decrement button is pressed for 10 seconds continuously, increment and decrement number become 100.

5.2 Observation of Software Revision on the Bottom Display When Power Is On

When the power is applied to the device all led indicators and display segments are momentarily illuminated for testing. Software revision number of the controller is momentarily illuminated on the bottom display.

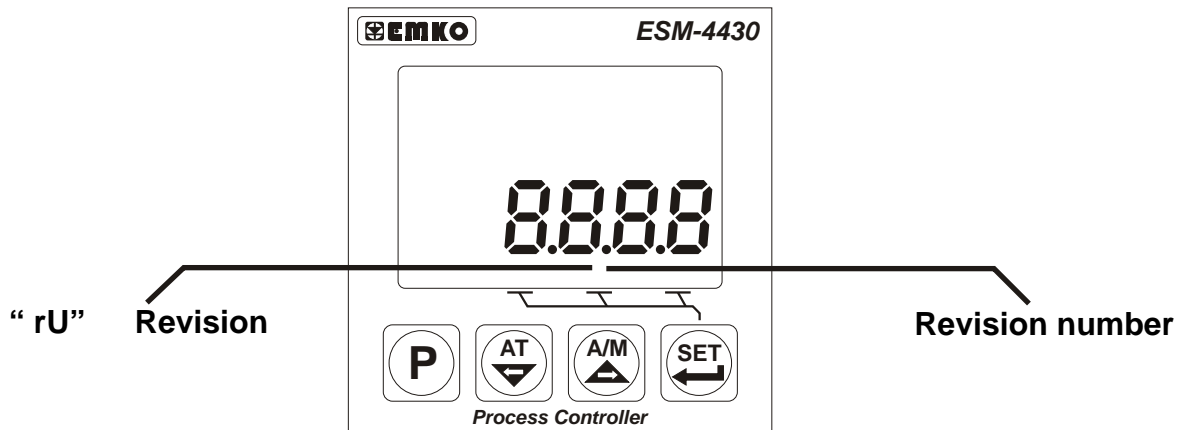

When power is on, display of the device is like below:

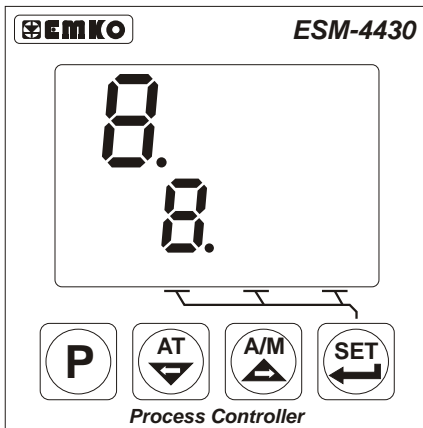

First segments of top and bottom displays are tested

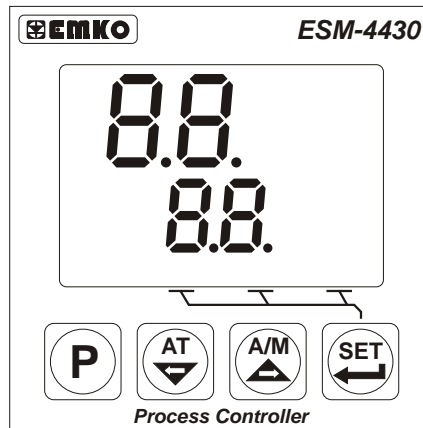

Second segments of top and bottom displays are tested.

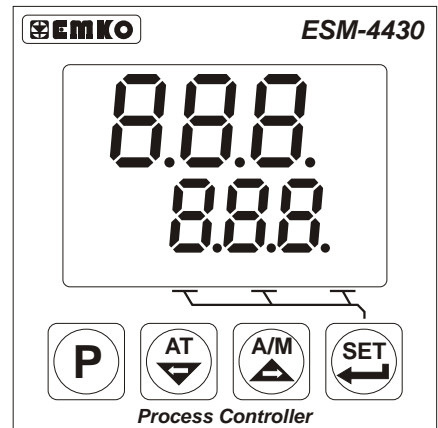

Third segments of top and bottom displays are tested.

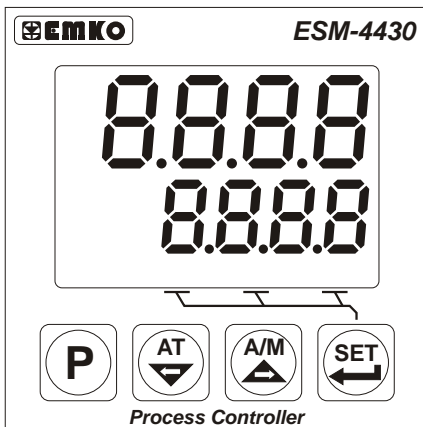

Fourth segments of top and bottom displays are tested.

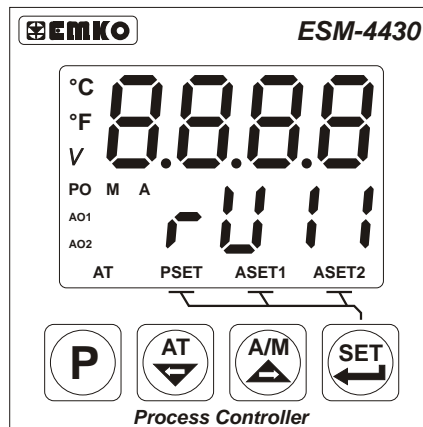

All leds are energised. On bottom display revision number is shown. Revision number is "11".

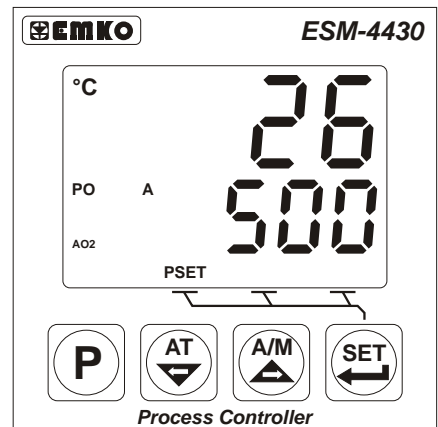

Main operation screen is shown



If there is an unexpected situation while opening the device, power off the device and inform a qualified personnel.

5.3 Adjustment of Process and Alarm Set Values

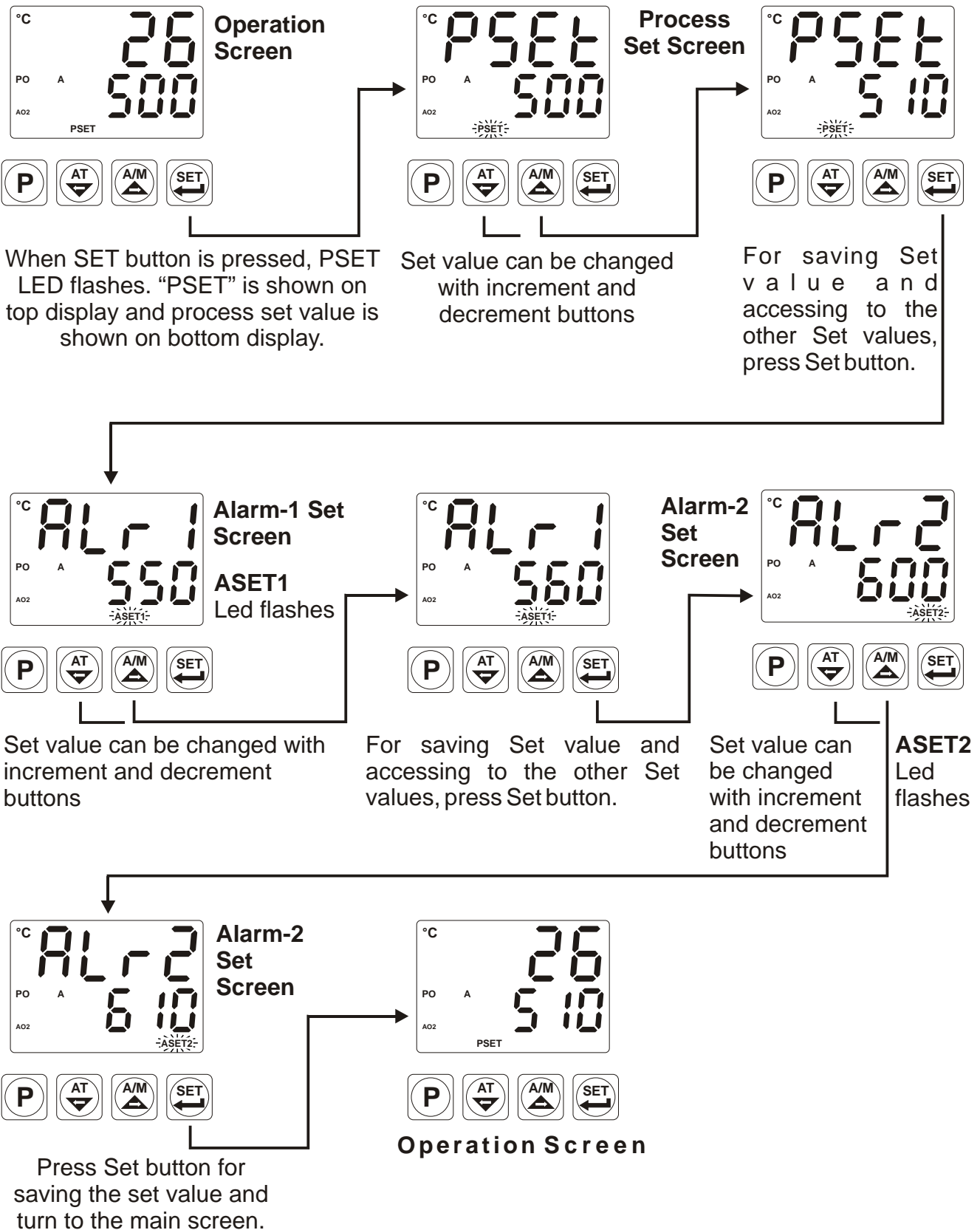

If ALr1 parameter in PCnF menu is 0 , ALr2 parameters is accessible. If it is 1 , this parameter is not accessible and device turns to the main operation screen



For exiting without saving Set value, press menu ("P") button.

5.4 Easy Access Diagram For Program Parameters

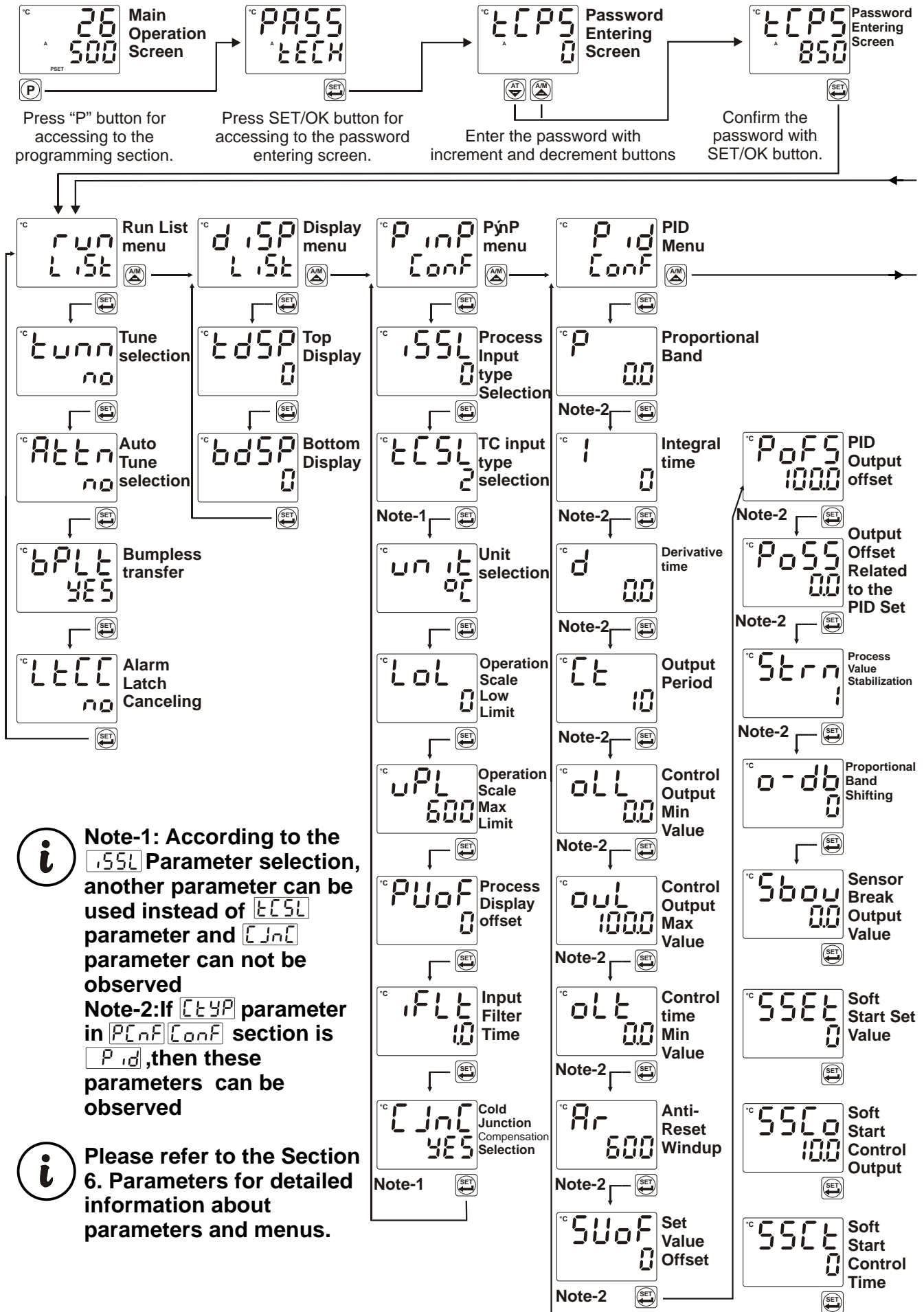

5.4 Easy Access Diagram For Program Parameters

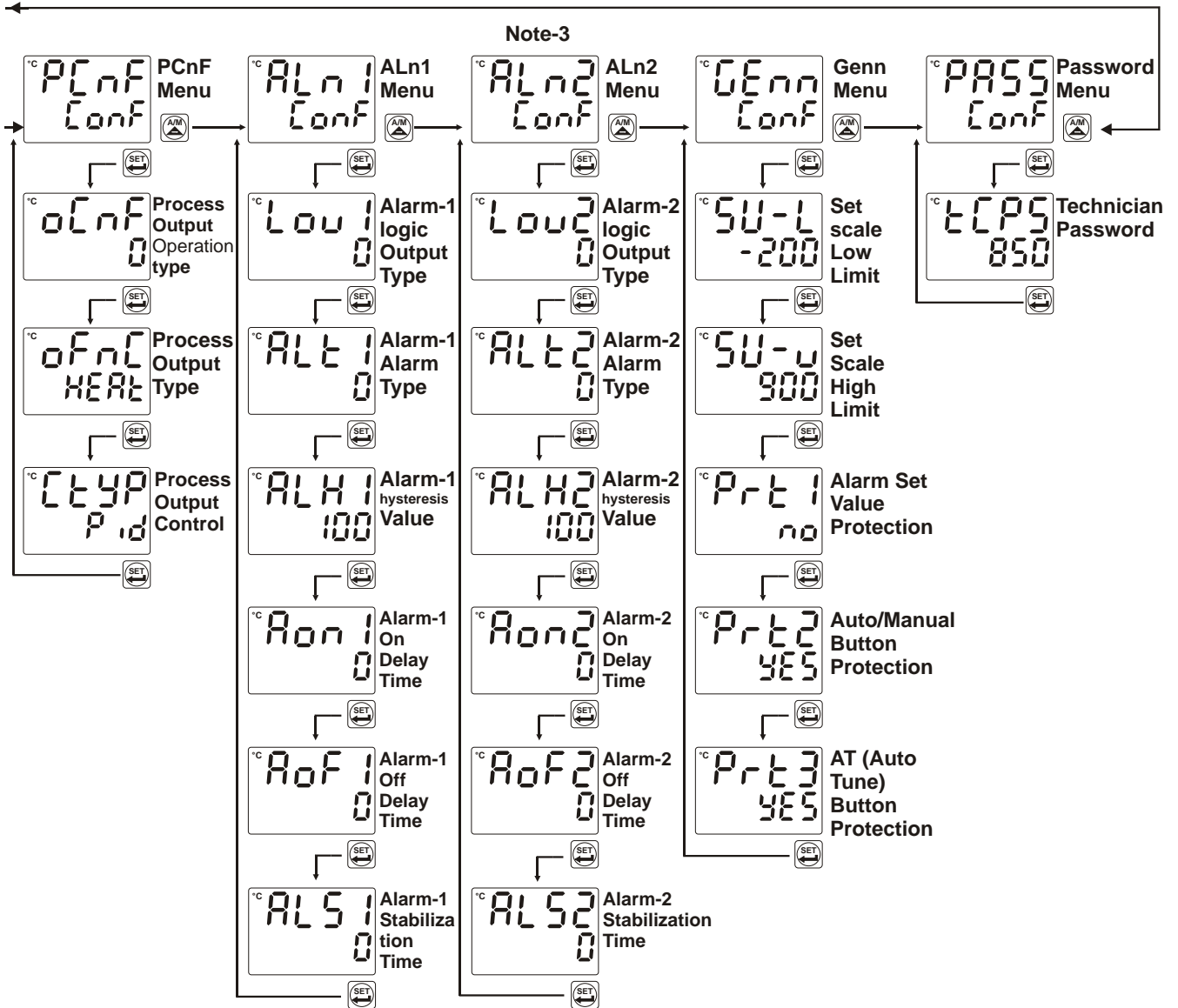

Note-3: This menu can be observed if **oCnF** parameter in **PCnF Conf** section is selected



Please refer to the Section 6. Parameters for detailed information about Parameters and menus.

5.5 Accessing to the Technician Menu

The parameters have been divided into groups according to their functions. Every group has a title and firstly user must determine the title (menu) for accessing to the parameters. Refer to the parameters section for detailed information about parameters.

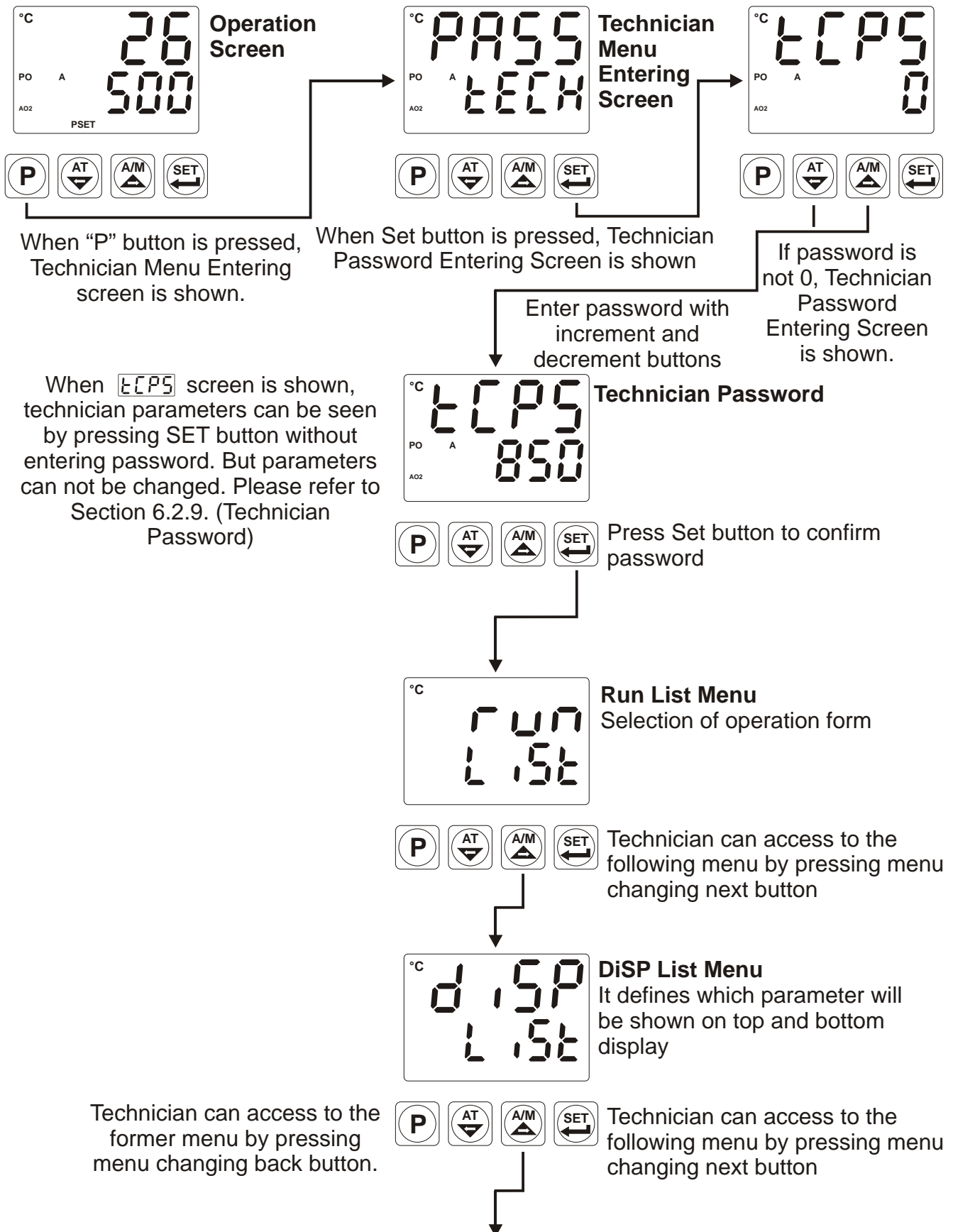

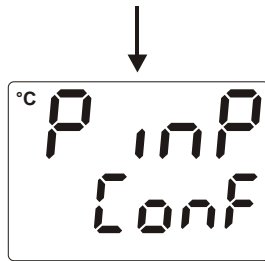

PINP CONF Menu
Configuration parameters of process input

Technician can access to the former menu by pressing menu changing back button.



Technician can access to the following menu by pressing menu changing next button

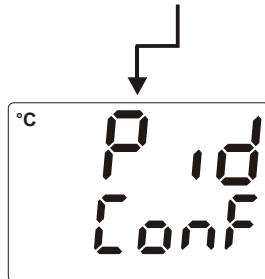

PID CONF Menu
PID algorithm parameters

Technician can access to the former menu by pressing menu changing back button.



Technician can access to the following menu by pressing menu changing next button

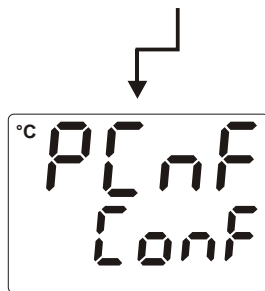

PCnF CONF Menu
Configuration parameters of Process outputs

Technician can access to the former menu by pressing menu changing back button.



Technician can access to the following menu by pressing menu changing next button

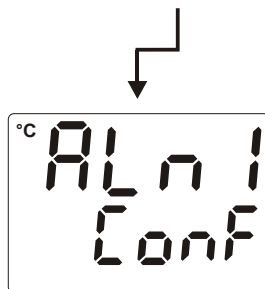

ALn1 CONF Menu
Configuration parameters of ALARM -1 output

Technician can access to the former menu by pressing menu changing back button.



Technician can access to the following menu by pressing menu changing next button

This parameter is accessible if **oCnF** parameter in PCnF menu is 0

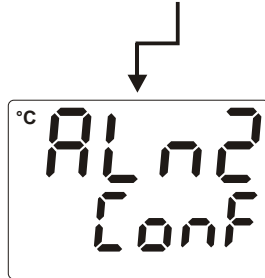

ALn2 CONF Menu
Configuration parameters of ALARM -2 Output

Technician can access to the former menu by pressing menu changing back button.



Technician can access to the following menu by pressing menu changing next button



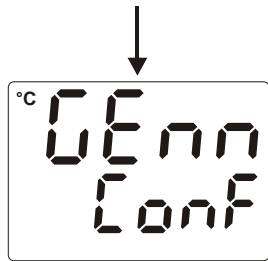

GENN CONF Menu
General parameters

Technician can access to the former menu by pressing menu changing back button.



Technician can access to the following menu by pressing menu changing next button

This menu is not accessible if Technician parameters are accessed by pressing SET button without entering technician password

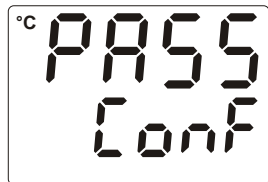

PASS CONF Menu
Technician password

Technician can access to the former menu by pressing menu changing back button.



Technician can access to the following menu by pressing menu changing next button

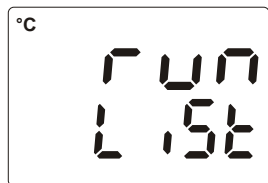

Run List Menu
After PASS CONF menu, beginning of the menu list is shown.

Technician can access to the former menu by pressing menu changing back button.



Press Menu button to exit from Menu list and turn back to operation screen

Continue to press menu changing next and back buttons to change the menu pages

By pressing SET button, technician can access to the menu page and all parameters in this menu page.

5.6 Changing and Saving Parameters

Example-1 : To change Process Input Type parameter 155L

Process Input Type parameter 155L is in "PynP Conf" menu, so PynP ConF menu must be accessed firstly in order to reach 155L parameter.

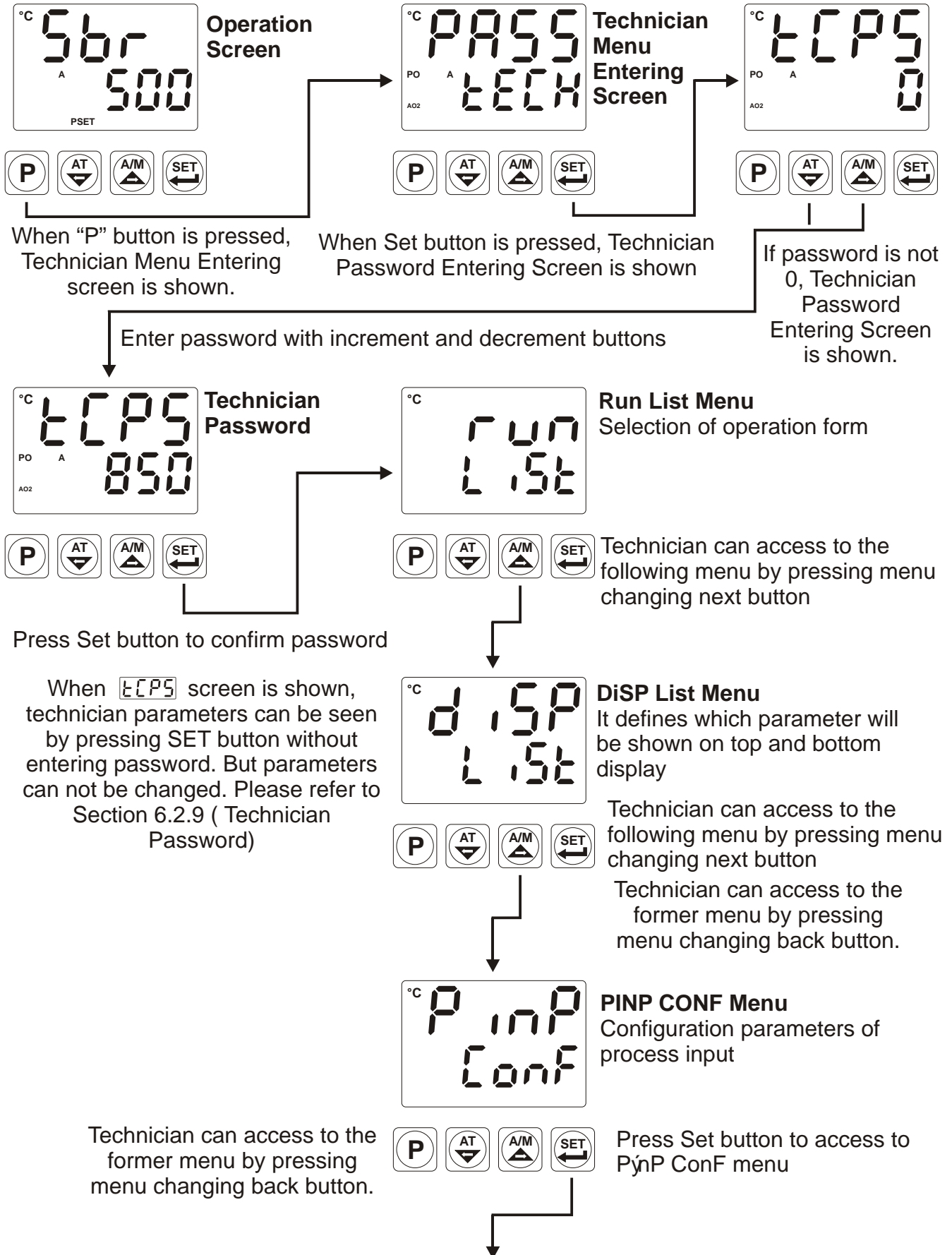

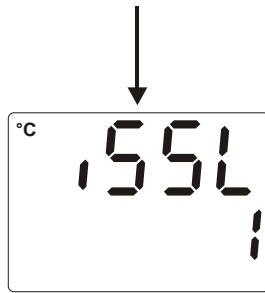

Process Input Type Selection
155.1 is [] means, input type is RTD.



Parameter can be changed with increment and decrement buttons

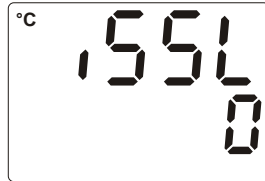

Process Input Type Selection
TC input type is selected



Press Set button to confirm the value and access to the next parameter.

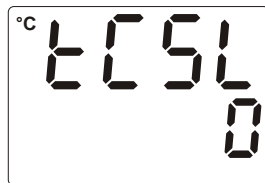

TC Input Type Selection

PINP CONF Menu
When Menu button is pressed, technician can access to the menu pages.



Press Set button to access to the next parameter

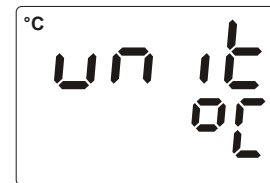
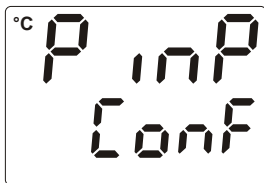

For accessing to the other menus, press menu changing next and back buttons.



Unit Selection

Press Menu button for turning to the operation screen

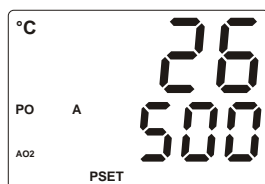

Operation Screen

Example-2 : Changing operation form from “Auto” to “Manual” and adjustment of % output.

If operation form is **Auto (Close-Loop Control)** and there is an output with PID or ON/OFF control form, device controls the process outputs by calculating the % output values automatically.

If operation form is **Manual (Open-Loop Control)** and there is an output with PID control form, then % output value can be adjusted with increment and decrement buttons.

If operation form is **Manual (Open-Loop Control)**, and there is an output with ON/OFF control form, then %output value can be adjusted OFF, HEAT or COOL with decrement and increment buttons.

If operation form is Manual, % output value is shown on bottom display whatever bdsP parameter is.



Auto/Manual Operation Form can be adjusted Auto or Manual with A/M button from front panel. For using this button, Auto/Manual Operation Type Selection Parameter Prt2 must be no . For details on this parameter, refer to Section 6.2.8 General Parameters.

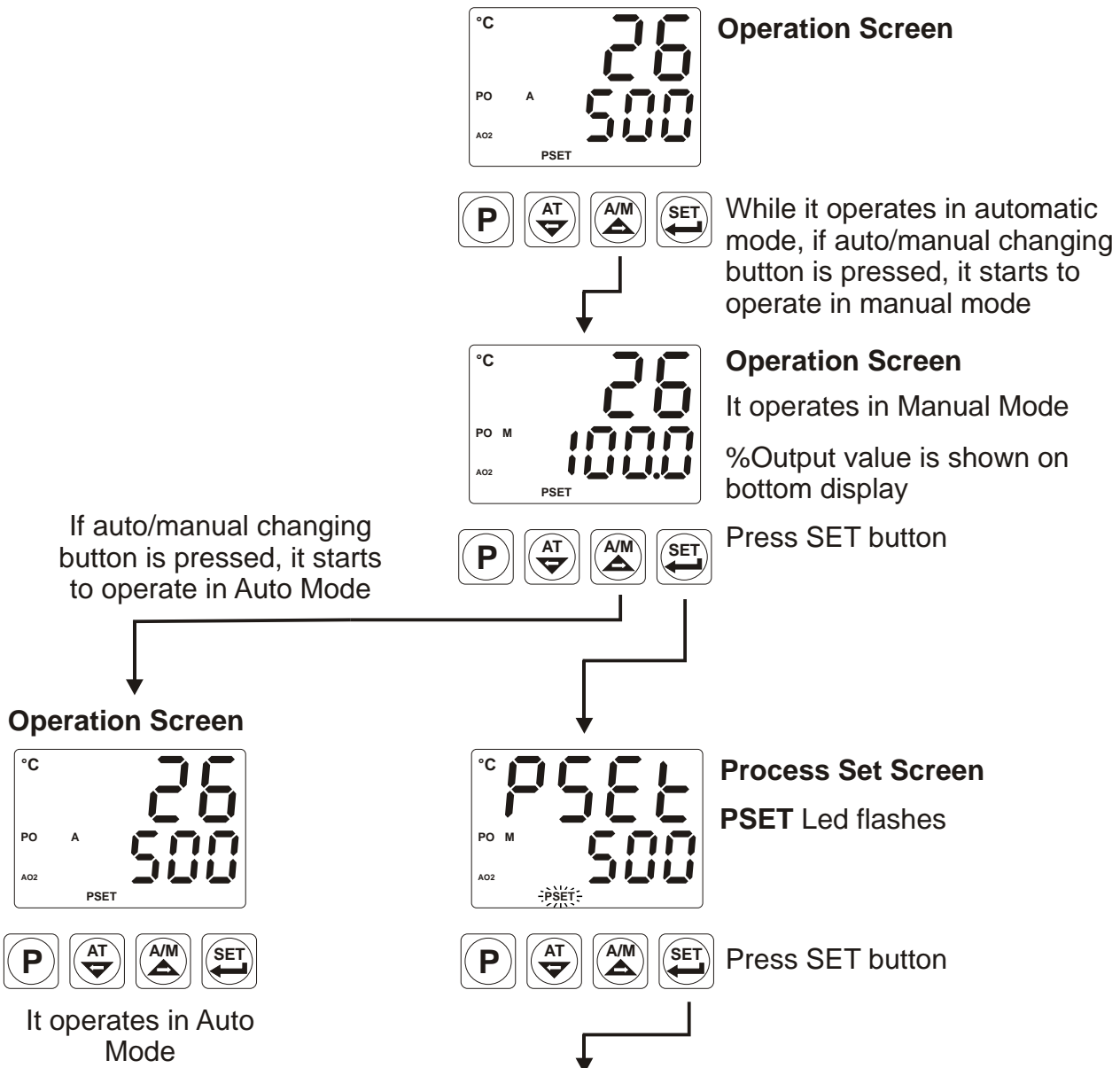

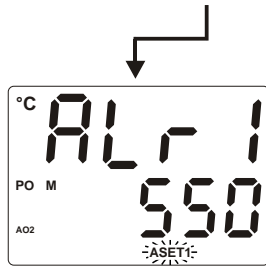

Alarm-1 Set Screen
ASET1 Led flashes



Press SET button

ASET2 Led flashes



Alarm-2 Set Screen

This parameter is accessible if `oCnF` parameter in PCnF menu is `0`. It is not accessible if `oCnF` Parameter is `1`



Press SET button

Manual Led flashes



Operation Screen

%Output value can be changed with increment and decrement buttons.



Operation Screen



Press Set button to confirm the value and turn to operation screen

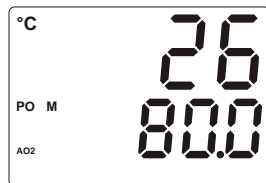

Manual Led stops flashing



Operation Screen

Example-3 : To change proportional band parameter P

Proportional band parameter P is in "P/d Conf" menu, so "P/d Conf" menu must be accessed firstly.

Operation Screen



When "P" button is pressed, Technician Menu Entering screen is shown.



When Set button is pressed, Password Entering Screen is shown



If password is not 0, Technician Password Entering Screen is shown.

Enter password with increment and decrement buttons

When $LCPS$ screen is shown, technician parameters can be seen by pressing SET button without entering password. But parameters can not be changed. Please refer to Section 6.2.9 (Technician Password)



Press Set button to confirm the password

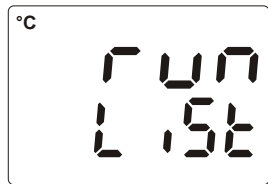

Run List Menu Selection of operation form



Technician can access to the following menu by pressing menu changing next button

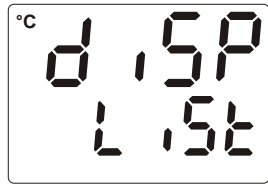

DiSP List Menu It defines which parameter will be shown on top and bottom display

Technician can access to the former menu by pressing menu changing back button.



Technician can access to the following menu by pressing menu changing next button



PINP CONF Menu
Configuration parameters of process input

Technician can access to the former menu by pressing menu changing back button.



Technician can access to the following menu by pressing menu changing next button

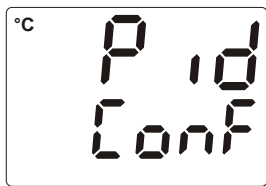

PID CONF Menu
PID algorithm parameters

Technician can access to the former menu by pressing menu changing back button.



Enter Set button to access to P_yd Conf menu



Proportional Band Selection



Parameter can be changed with increment and decrement buttons

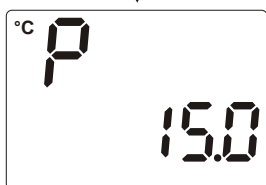

Proportional Band Selection



Press Set button to confirm the value and access to the next parameter



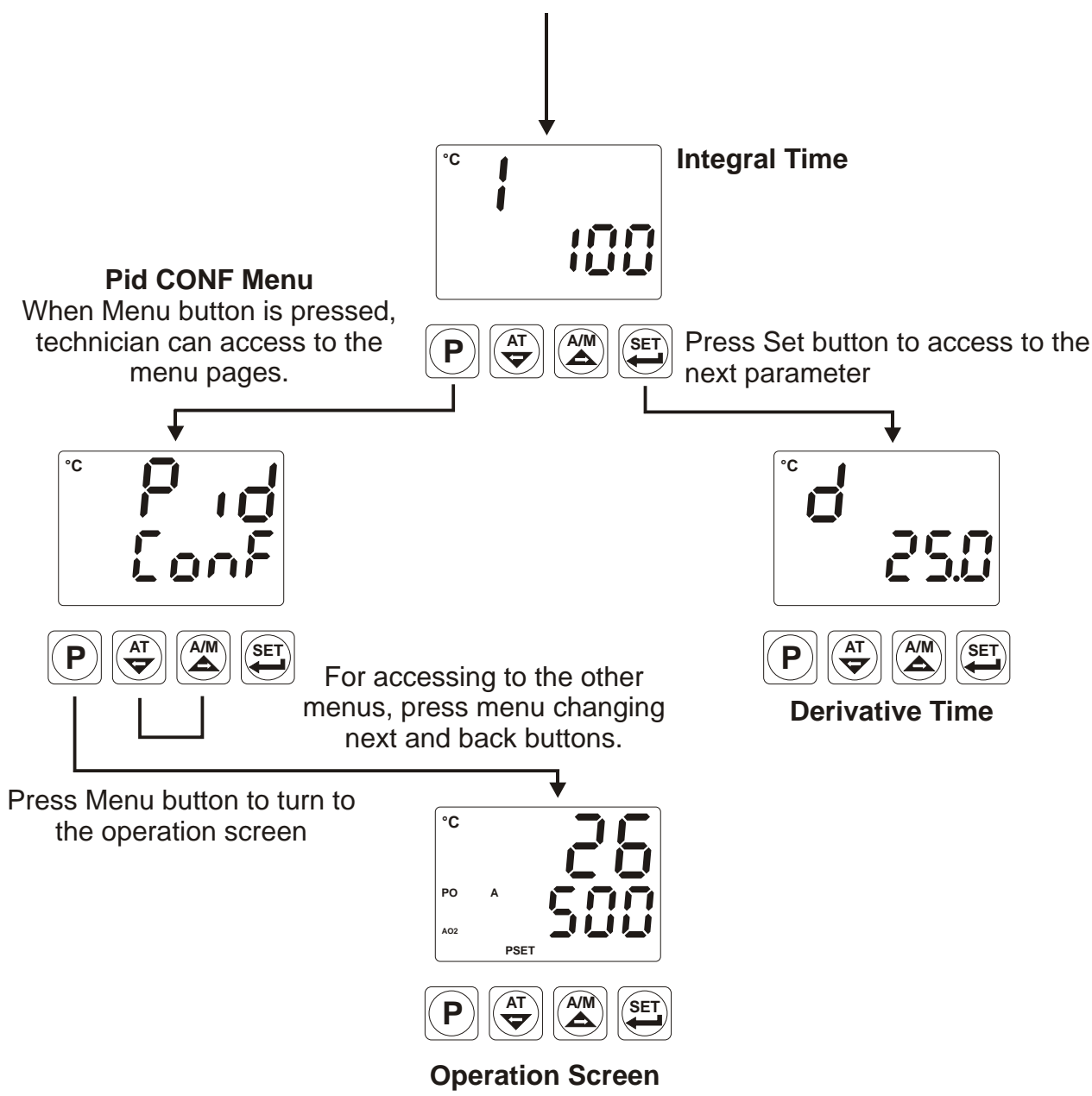

Example-4 : To change \pm Voltage / Current Input Calibration Type Selection parameter

\pm CAL in "P \pm nP ConF" menu

\pm CAL Parameter is in "P \pm nP ConF" menu. For accessing to this parameter, technician must access to "P \pm nP ConF" menu firstly. In this example, changing input type of a device from thermocouple to \pm Voltage / Current and dual point calibration selection is shown.

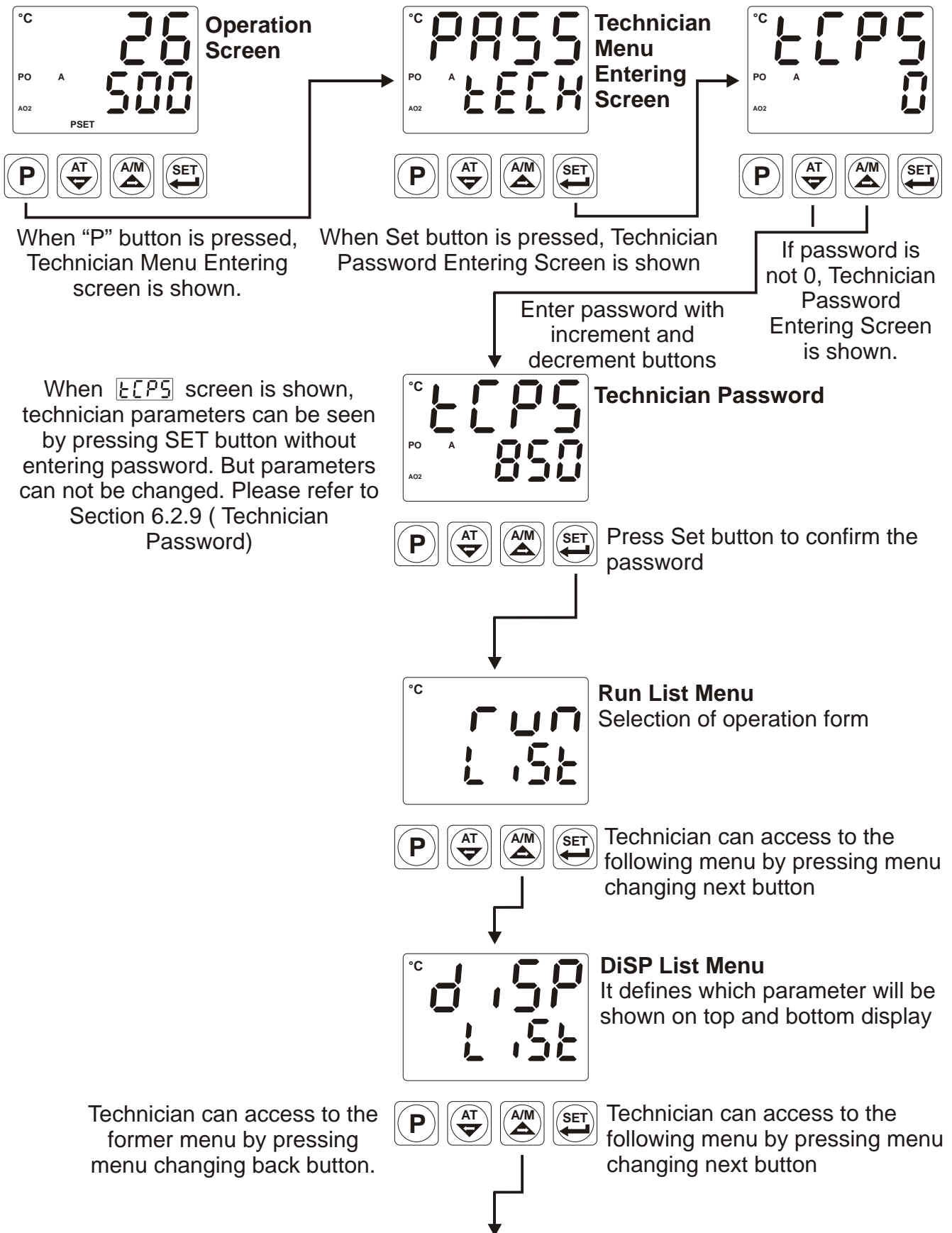

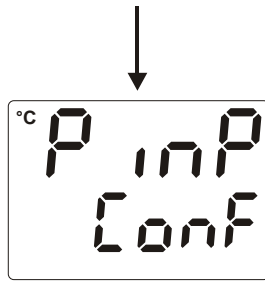

PINP CONF Menu
Configuration parameters of process input

Technician can access to the former menu by pressing menu changing back button.



Enter P_{in}P ConF menu by pressing Set button

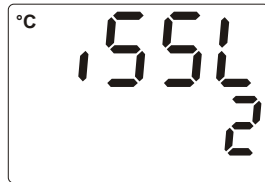

Process Input Type Selection
For accessing to uCAL parameter, 155L parameter must be 2. If it is not 2, change the value as 2 with increment button.



Press Set button to confirm the value and access to the next parameter

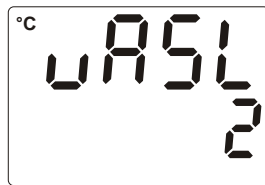

---Voltage / Current Input Type Selection



Press Set button to access to the next parameter

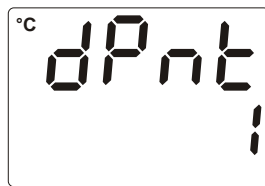

Decimal Point Position



Press Set button to access to the next parameter

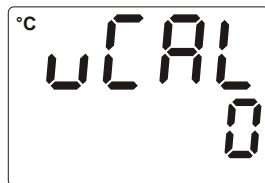





---Voltage / Current Input Calibration Type Selection

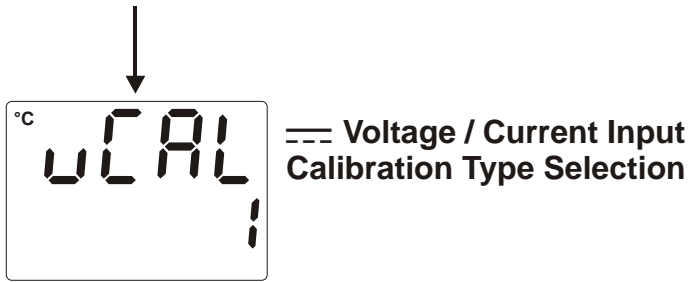





Parameter can be changed with increment and decrement buttons







 Press Set button to confirm the value and access to the next parameter



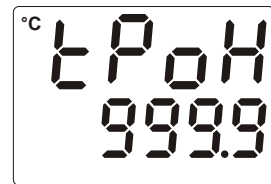
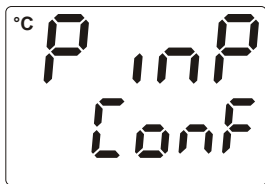



 Press Set button to access to the next parameter

PINP CONF Menu
When Menu button is pressed, technician can access to the menu pages



For accessing to the other menus, press menu changing next and back buttons.



Press Menu button to turn to the operation screen

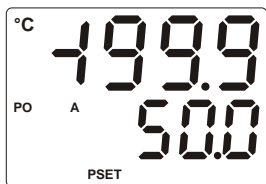

Operation Screen

6. Parameters

Parameters are divided into two groups. They are Process / Alarm Set parameters and Technician parameters. Technician parameters are grouped into subgroups according to their functions. The subgroups are named as menu pages.

6.1 Process / Alarm SET Parameters

PSET Process set value
PSET Process set value can be adjusted from minimum value of set scale **SU-L** to maximum value of set scale **SU-U**

ALr1 Set value for alarm output-1
ALr1 Process set value can be adjusted from minimum value of set scale **SU-L** to maximum value of set scale **SU-U**

ALr2 Set value for alarm output-2. It is accessible if **oCnF** parameter is
ALr2 Process set value can be adjusted from minimum value of set scale **SU-L** to maximum value of set scale **SU-U**



For changing Alarm Output-1 and Alarm Output-2 Set values, Alarm Set Values protection parameter **PrEt1 must be**

run
LIST

6.2.1 Selection of PID Tune and Operation Form

tunn

TUNE SELECTION

By selecting one of the methods below, device can determine the PID parameters.

no

Device operates according to the defined PID parameters

Atun

Auto tune (Limit Cycle Tuning) operation

Stun

Self tune (Step Response Tuning) operation

AtSt

Auto-Self Tune

Self Tune operation is performed, if the conditions are realized when power on firstly. In normal operation, it controls the tune conditions in **Auto Tune** selection which explained below. If any of the conditions is realized, it performs the **Auto Tune** operation.

Attn

AUTOMATIC TUNE SELECTION

no

Device does not do **Atun** (Limit Cycle Tuning) operation or while **Atun** operation runs, this selection is adjusted **no** and **Auto Tune** operation is canceled.

YES

If **tunn** parameter is **Atun** or **AtSt**, when the conditions for Auto Tune parameter that are explained in Tune Methods section are realized, it starts to perform Auto Tune (Limit Cycle Tuning) operation.



By pressing AT button, Automatic Tune can be selected **YES** or **no**. For being able to use AT button, AT (Auto Tune) Button protection parameter **Prt3** must be **no**. (For details, refer to Section 6.2.8 General Parameters)

TUNE METHODS

There are 2 different methods for determining PID parameters by the device. These are **Auto tune** (Limit Cycle Tuning) and **Self Tune** (Step Response Tuning) methods.

Determining of PID parameters with **Auto Tune** is started in these conditions :

- 1- By the user in any time,
- 2- By the device when system gets unstable and starts oscillation

If process value is out of **Set ± Process value stabilisation** value (Please refer to Section 6.2.4) and starts to oscillates, then device changes the Parameter to and Auto Tune operation is started.

3- After changing set value, if difference between newly defined set value and former set value is greater than proportional band, device will start it.

If set value is changed to a value that is greater than;

\pm [Scale * (Heating or Cooling Proportional Band)]/1000 value,

Parameter is adjusted by the device and **Auto Tune** operation is started.

Example -1 : Starting Auto Tune operation by the user ;

- Enter technician menu.
- Adjust tune selection parameter in "run List" menu , **Auto Tune** or **Auto-Self Tune**
- Adjust automatic tune selection parameter in "run List" menu and return to main operation screen.
- Observe that "AT" led is active.

If **Auto Tune** operation finishes without any problem, device saves the PID coefficients to memory and continue to run. Parameter is adjusted automatically.

Canceling **Auto Tune** operation:

1- If sensor breaks ;

2- If **Auto Tune** operation can not be completed in 8 hours

3- If user adjusts parameter or

4- If user adjusts parameter

5- If process set value is changed while Tune operation is being performed

6- While Tune operation is being performed, if operation type selection is changed as "Manual" when it is "Automatic" (If operation type selection is changed as "Automatic" when it is "Manual", then Tune operation is started again)

7- If output function is changed while Tune operation is being performed (Heat Cool, Cool Heat)

8- While Tune operation is being performed, if control form is changed as "ON/OFF" when it is "PID" (If control form is changed as "PID" when it is "ON/OFF", the Tune operation is started again)

Auto Tune is canceled. Then, without doing any changes in PID parameters, device continues to run with former PID parameters.



For Auto Tune (Limit Cycle Tuning) operation :

1- Tune selection parameter in "run List" menu must be selected **Auto tune** or **Auto-Self tune** .

2 - For being started Tune operation (Auto Tune or Self Tune) control form must be P, PI, PD or PID.

3 - If process set value is changed while Tune operation is being performed, Tune operation is canceled.

Auto Tune (Limit Cycle Tuning) operation ;
 if heating or heating-cooling function and PID control form is selected, process control output runs according to heating
 if cooling function and PID control form is selected, process control output runs according to cooling .

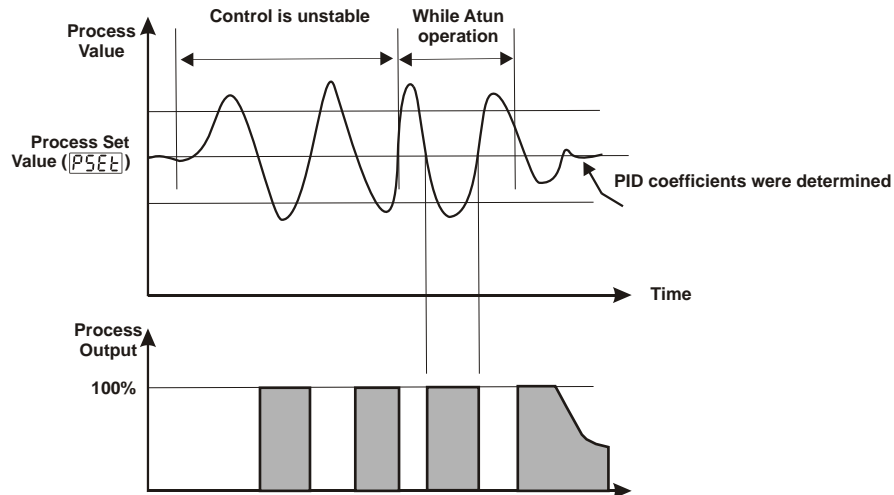

Self Tune (Step Response Tuning) :

When power is on, while process value starts to change for being equal to process set value, PID parameters are determined by the device with **Self Tune** method.

For starting **Self Tune (Step Response Tuning)** operation firstly power off and then apply power to the device. Also difference between process value and set value must be too much.

Example 2 : Determination of PID parameters with Self Tune method

- Enter technician menu
- Select tune selection parameter `tunn` in “run List” menu `Stun` or `AtSt` and turn to operation screen.
- Power off the device.
- Wait system to be in first conditions.
(For example : Decrease of the temperature to ambient temperature while controlling the temperature)
- Apply power to the device
- See that “AT” led is active

If heating or heating-cooling function and PID control form is selected for the system;

If set value is greater than process value, process output becomes active till to the **Temperature+[(Set - Temperature) / 2]** value. When process value reaches to this value, process output reduces to 0% and it calculates the PID coefficients.

For Self Tune (Step Response Tuning) operation :

- 1 - Tune selection parameter `tunn` in “run List” menu must be selected **Self tune** `Stun` or **Auto-Self Tune** `AtSt`
- 2 - For **Self Tune (Step Response Tuning)** operation, firstly power off and then apply power to the device.
- 3 - For being started Tune operation (Auto Tune or Self Tune) control form must be P, PI, PD or PID.
- 4 - If process set value is changed while Tune operation is being performed, Tune operation is canceled.



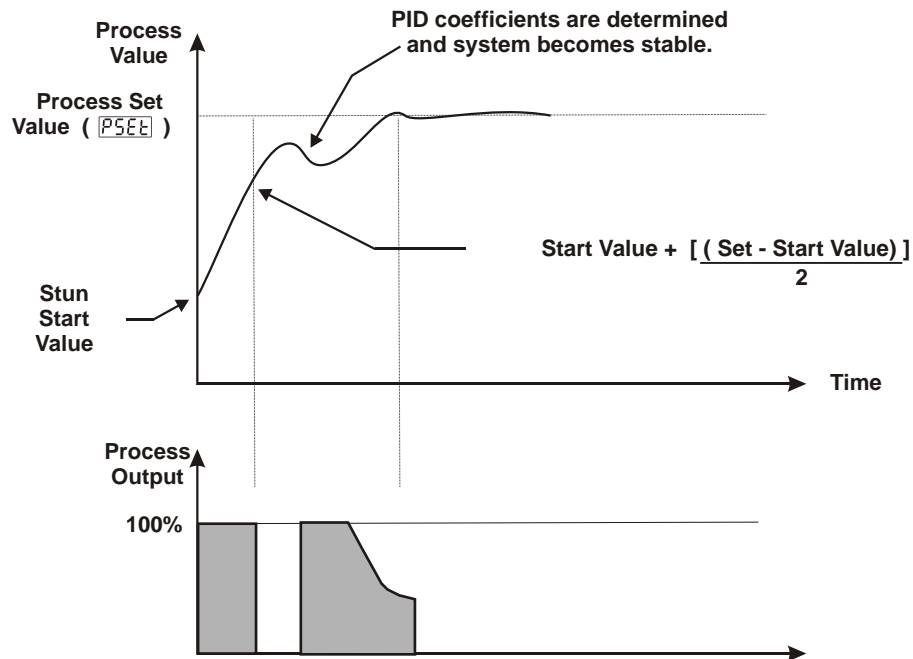

If cooling function and PID control form is selected for the system;
 If set value is less than process value, process output becomes active till to the **Temperature - [(Temperature-Set) / 2]** value. When process value reaches to this value, process output is reduced to 0% and it calculates PID coefficients.

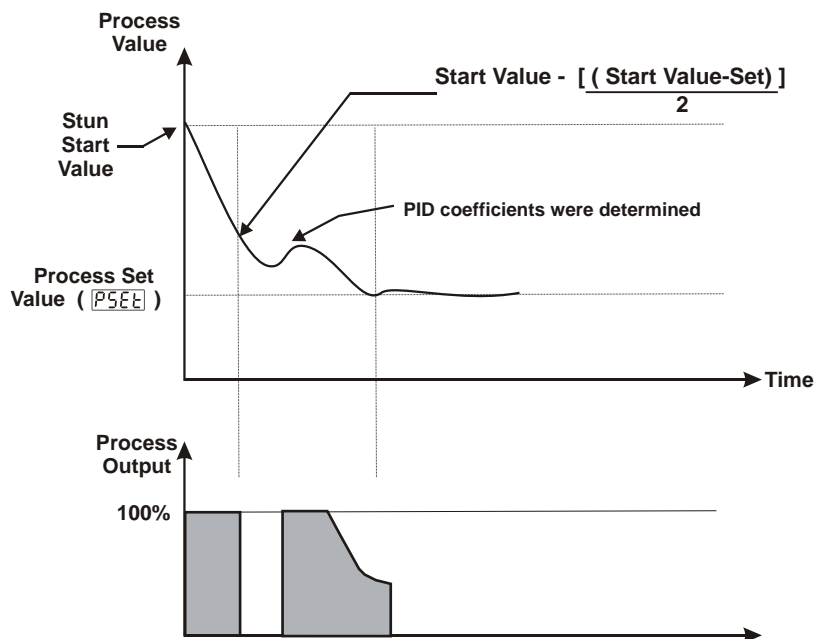

For Self Tune (Step Response Tuning) operation :



- 1 - Tune selection parameter `tunn` in "run List" menu must be selected **Self tune** `Stun` or **Auto-Self Tune** `ALSt`
- 2 - For **Self Tune (Step Response Tuning)** operation, firstly power off and then apply power to the device.
- 3 - For being started Tune operation (Auto Tune or Self Tune) control form must be P, PI, PD or PID.
- 4 - If process set value is changed while Tune operation is being performed, Tune operation is canceled.

If **Self Tune** operation is finished without any problem, device saves new PID parameters to memory and runs. It changes `TUNE` parameter.

If `TUNE` parameter is `SETUN` it is changed to `NO` , if it is `REST` , it is changed to `RESTUN`

If **Self Tune** operation is interrupted at half, PID parameters and `TUNE` parameter are not changed, device continues to run with former PID parameters. When power is off and then on, device starts to complete the **Self Tune** operation.

Canceling **Self Tune** operation :

- 1- If sensor breaks ;
- 2- If **Self Tune** operation can not be completed in 8 hours ;
- 3- While heating **Self Tune** operation is running, if process value becomes greater than Set value ;
- 4- While cooling **Self Tune** operation is running, if process value becomes less than Set value ;
- 5- If user selects `TUNE` parameter `NO` or `RESTUN`
- 6- If process set value is changed while Tune operation is being performed
- 7- While Tune operation is being performed, if operation type selection is changed as "Manual" when it is "Automatic"
- 8- If output function is changed while Tune operation is being performed (Heat Cool, Cool Heat)
- 9- While Tune operation is being performed, if control form is changed as "ON/OFF" when it is "PID" (If control form is changed as "PID" when it is "ON/OFF", the Tune operation is started again)

Self Tune operation is canceled. Then device continues to run with former PID parameters without changing PID parameters.



For Self Tune (Step Response Tuning) operation :

- 1 - Tune selection parameter `TUNE` in "run List" menu must be selected **Self tune** `SETUN` or **Auto-Self Tune** `REST`
- 2 - For **Self Tune (Step Response Tuning)** operation, firstly power off and then apply power to the device.
- 3 - For being started Tune operation (Auto Tune or Self Tune) control form must be P, PI, PD or PID.
- 4 - If process set value is changed while Tune operation is being performed, Tune operation is canceled.

bPLt

BUMPLESS TRANSFER

no

Process output value in manual control is not taken into consideration while passing from manual control to automatic control. New control output that is measured in automatic control is applied to process output.

Last %output value is taken output value of manual control and manual control continues while passing from automatic control to manual control.

YES

While passing from manual control to automatic control, last process output value in manual control is accepted as first process output value in automatic control and automatic control continues to run.

Last % process output value in automatic control is accepted as process output value of manual control and manual control continues to run.

LtCC

ALARM LATCH CANCELING

no

Alarm latch canceling is not performed.

YES

If there is an alarm output with latching and there is no alarm status, latching operation will be finished by the device. When it is finished, this parameter becomes no Automatically.

d.5P

L.5t

6.2.2 Function Selection for Top and Bottom Display

tdSP

It defines the function of the top display. This parameter determines which value is shown in top display.

0

Process value (PV) is shown in top display.

!

Difference between process set value and process value (SV-PV) is shown in top display.

bdSP

It defines the function of the bottom display. This parameter determines which value is shown in bottom display.

0

Process set value (SV) is shown in bottom display.

!

%Output value that is applied to process control output is shown in bottom display.

P_{inP}

Conf

6.2.3 Process Input Type and Relevant Parameters with Process Input

.55L

Defines the process input type.

0

TC input type selection

1

RTD input type selection

2

---Voltage / Current input type selection.

.55L

TC5L

Defines type and scale of the thermocouple for TC input. It is active if TC input type is selected.

0

L (-100°C;850°C) or (-148°F;1562°F)

1

L (-100.0°C;850.0°C) or (-148.0°F;999.9°F)

2

J (-200°C;900°C) or (-328°F;1652°F)

3

J (-199.9°C;900.0°C) or (-199.9°F;999.9°F)

4

K (-200°C;1300°C) or (-328°F;2372°F)

5

K (-199.9°C;999.9°C) or (-199.9°F;999.9°F)

6

R (0°C;1700°C) or (32°F;3092°F)

7

R (0.0°C;999.9°C) or (32.0°F;999.9°F)

8

S (0°C;1700°C) or (32°F;3092°F)

9

S (0.0°C;999.9°C) or (32.0°F;999.9°F)

10

T (-200°C;400°C) or (-328°F;752°F)

11

T (-199.9°C;400.0°C) or (-199.9°F;752.0°F)

12

B (44°C;1800°C) or (111°F;3272°F)

13

B (44.0°C;999.9°C) or (111.0°F ; 999.9°F)

14

E (-150°C;700°C) or (-238°F;1292°F)

15

E (-150.0°C;700.0°C) or (-199.9°F;999.9°F)

16

N (-200°C;1300°C) or (-328°F;2372°F)

17

N (-199.9°C;999.9°C) or (-199.9°F;999.9°F)

18

C (0°C;2300°C) or (32°F;3261°F)

19

C (0.0°C;999.9°C) or (32.0°F;999.9°F)

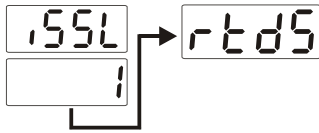

Defines type and scale of sensor for RTD input. It is active if RTD input is selected.

PT-100 (-200°C ; 650°C) or (-328°F ; 1202°F)

PT-100 (-199.9°C ; 650.0°C) or (-199.9°F ; 999.9°F)

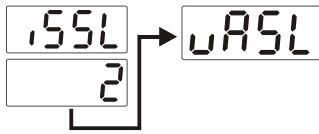

Defines input range and scale of μ Volt / Current input. It is active if μ Volt / Current is selected.

0...50mV μ (-1999 ; 9999)

0...5V μ (-1999 ; 9999)

0...10V μ (-1999 ; 9999)

0...20mA μ (-1999 ; 9999)

4...20mA μ (-1999 ; 9999)



Defines point position for displays. It is active if μ Volt / Current input is selected.

No point

Between first and second digits "0.0"

Between second and third digits "0.00"

Between third and fourth digits "0.000"



It is active when μ Volt / Current input is selected. It determines calibration type.

Fixed dual point calibration is done. It does not allow to adjust minimum and maximum value of calibration points. It can be adjusted from -1999 to 9999

It allows to do selectable dual point calibration.

It allows to define 16 calibration points.

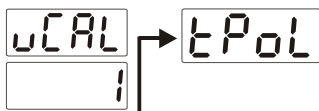

It defines minimum value for selectable dual point calibration. It is active if μ Volt / Current input is selected. It can be adjusted from -1999 to 9999.

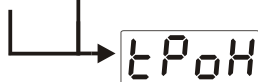

It defines maximum value for selectable dual point calibration. It is active if μ Volt / Current is selected. It can be adjusted from -1999 to 9999.

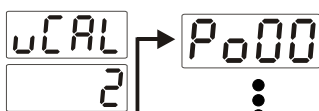

In multi point calibration, calibration points are defined with these parameters.

It is active if μ Volt / Current is selected. It can be adjusted from -1999 to 9999.



In multi point calibration operation, defined scale is divided into 16 calibration points.

For example : μ ASL is (0-50 mV μ).

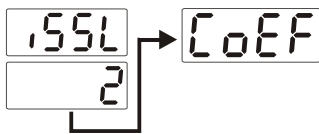
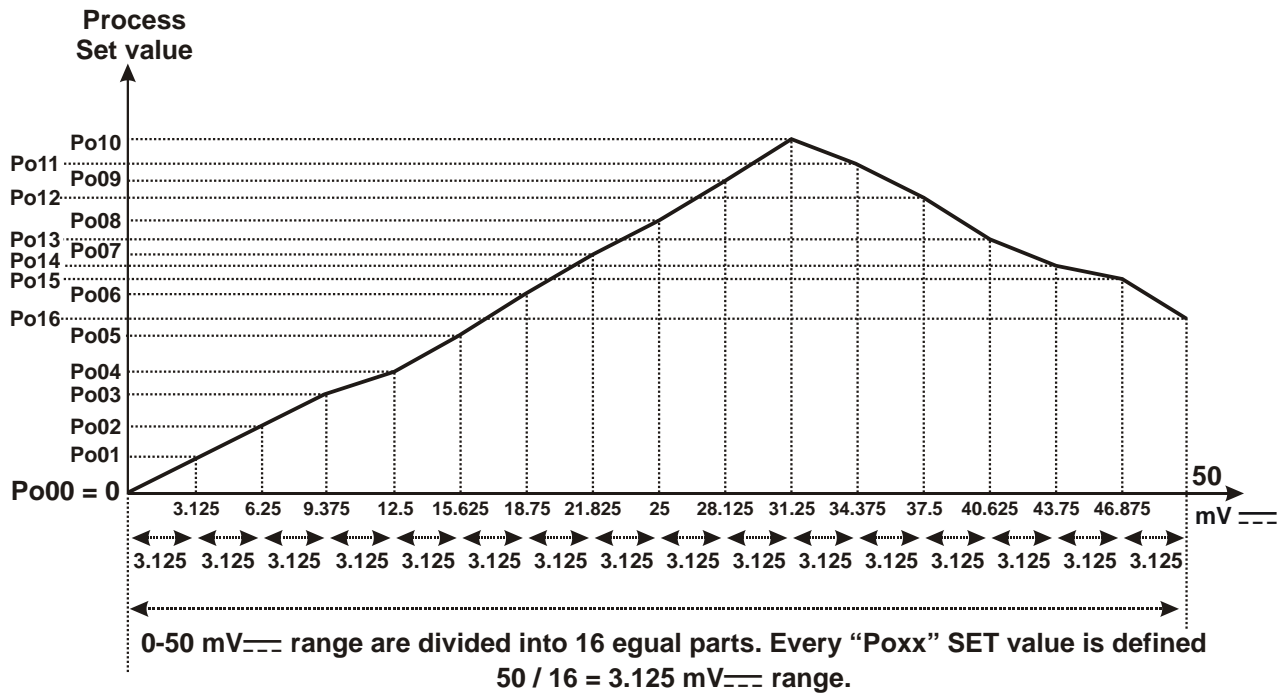

COEF Coefficient value for Voltage / Current input. Process value is multiplied with this value. It is active if Voltage / Current input is selected. It can be adjusted from 1.000 to 9.999.



unit Unit selection

Unit is °C

Unit is °F

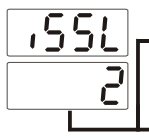

Unit is U. It is active if Voltage / Current input is selected

No unit. It is active if Voltage / current input is selected



LoL Minimum value of operating scale. It can be changed according to input type and scale of the process.



uPL Maximum value of operating scale. It can be changed according to input type and scale of the process.



PUoF Display offset for process value. It can be adjusted -10% to +10% of scale. The defined value is added to process value.



iFLT Defines filter time for input signal. It can be adjusted from 0.0 to 900.0.

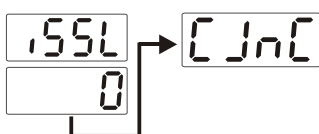

CJnC It is active if process input is selected TC input. It decides if cold junction compensation is active or not.

Cold junction compensation is active.

Cold junction compensation is not active.

P id

Conf

6.2.4 PID Configuration Parameters

If any output is configured as heating PID ;

P , I , d , Ct , oLL , ouL , oLt , Ar , SUoF , PoFS , PoSS , Strn , o-db , Sbow parameters are accessible

If no output is configured as PID ;

Only o-db , Sbow parameters are accessible in PID CONF menu.

P

PROPORTIONAL BAND (0.0% , 999.9%)

Full Scale (uPL - LoL) %.

If uPL = 1000 °C, LoL = 0 °C and P = 50.0 then

Proportional Band = (uPL - LoL) * P / 100.0

Proportional Band = (1000-0)*50.0/100.0 = 500 °C

I

INTEGRAL TIME (0 sec, 3600 secs)

It can be changed by the user. When Tune operation stops, it can be changed by the device. If it is 0, integral control part does not run. When tune operation stops if this parameter is 0, this parameter can not be changed because of integral control part does not run.

d

DERIVATIVE TIME (0.0 sec, 999.9 secs)

It can be changed by the user. When Tune operation stops, it can be changed by the device. If it is 0, derivative control part does not run. When tune operation stops if this parameter is 0, this parameter can not be changed because of derivative control part does not run.

Ct

CONTROL PERIOD TIME (1 sec, 150 secs)

It is control period

IF
PCnf
Conf

↓
CtYP

↓
P id

IS
SELECTED

OUTPUT : ON

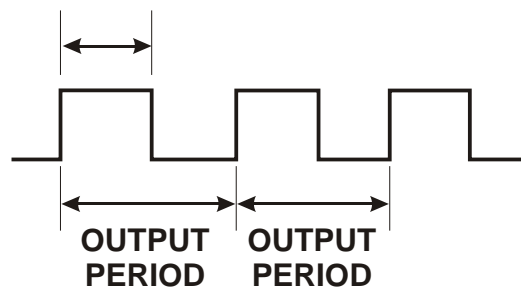

Relay Output : Output period must be short for stable process control. Relay must not be used in short output periods because of limited life of their relay contact (number of open/close events). Relay output must be used as control output in values near to 30 seconds or greater than this value.

SSR Output : If short output period is needed in a system (approximately 1-2 seconds) SSR driver output as last control element is recommended.

oll

MINIMUM CONTROL OUTPUT (0.0% , ouL)

It is % of minimum output.

Even as a result of the PID calculation device calculates the %output value less than this parameter, heating or cooling output is active minimum for OLL parameter.

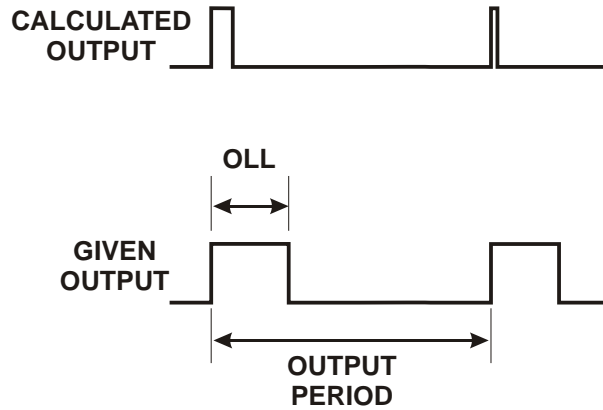

oul

MAXIMUM CONTROL OUTPUT (oll , 100.0%)

It is % of maximum output.

Even as a result of the PID calculation device calculates the %output value greater than this parameter, heating or cooling output is active maximum for OULH parameter.

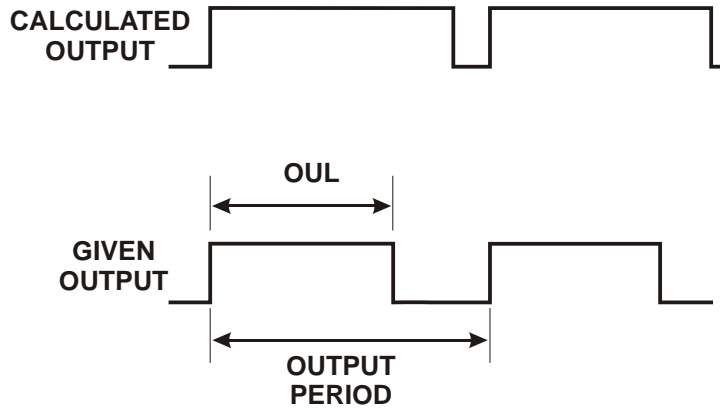

olt

MINIMUM CONTROL OUTPUT TIME (0.0 sec , et)

Heating or cooling output can not be active less than this parameter. Even if this parameter is 0, this parameter is accepted 50 msecs for security.

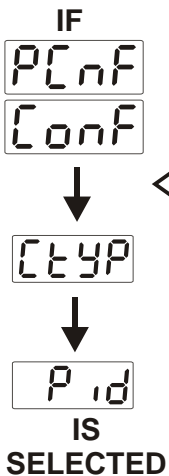

Ar

ANTI-RESET WINDUP (0, SCALE HIGH POINT)

While PID operation is running if

$PSET - Ar \leq \text{process value} \leq PSET + Ar$ condition is true, integral value is calculated. If the condition is not true, integral value is not calculated and last calculated integral value is used.

Scale High Point : Maximum process input value in Pt-100 and Tc inputs

9999 for fixed dual point calibration used inputs,

Scale high point is the biggest one from $LPOL$ or $LPKH$ for selectable dual point calibration used inputs

Scale high point is the biggest one from $PODD$ or $PO15$ for multi point calibration used inputs

Note: Point position changes according to process input type and scale, unit changes according to the selection in $unit$ parameter.

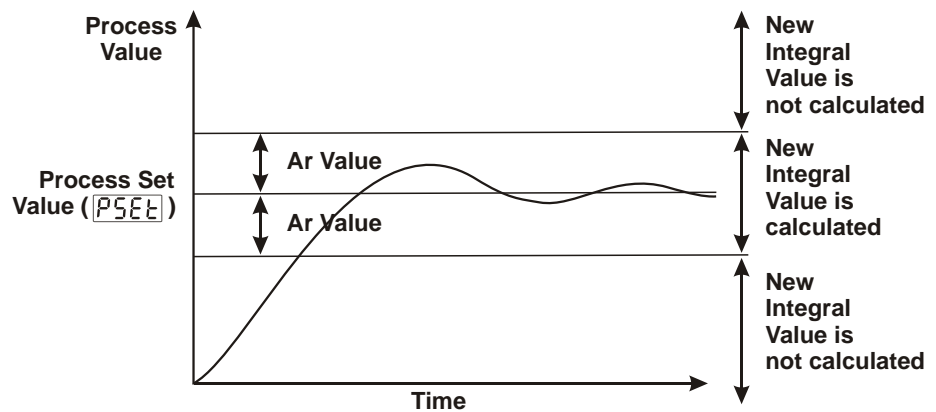

IF
PCNF
CONF
↓
CTYP
↓
PID
IS
SELECTED

Suof

SET VALUE OFFSET

$((- \text{SCALE HIGH POINT} / 2), (\text{SCALE HIGH POINT} / 2))$

$PSET + Suof$ is used as set value in PID calculations. It is used for shifting the proportional band.

Example: If $PSET = 500^\circ\text{C}$, $Suof = 5^\circ\text{C}$ or $Suof = -5^\circ\text{C}$, shifting of the proportional band is shown below :

Note: Point position changes according to process input type and scale, unit changes according to the selection in $unit$ parameter.

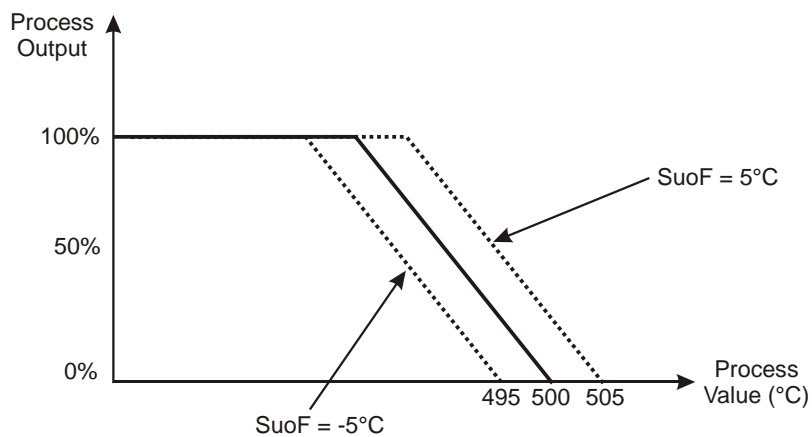

PoFS

PID OUTPUT OFFSET

(FOR HEATING PID 0.0%, 100.0%)
(FOR COOLING PID -100.0%, 0.0%)

This parameter is added to "Output %" which is calculated at the end of the PID.

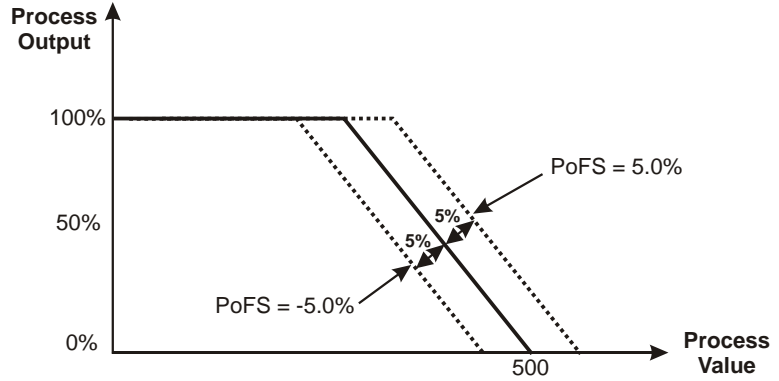

PoSS

OUTPUT OFFSET RELATED TO PID SET

(FOR HEATING PID 0.0%, 100.0%)
(FOR COOLING PID -100.0%, 0.0%)

This parameter is added to the %process output that is calculated at the end of the PID according to process set value.

$$PoSS * PSet / (uPL - LoL)$$

Example If $PSet = 500^{\circ}C$, $uPL = 1000^{\circ}C$, $LoL = 0$, $PoSS = 5.0\%$ then $PoSS * PSet / (uPL - LoL) = 5.0 * 500 / (1000 - 0) = 2.5\%$ 2.5% is added to calculated process value.

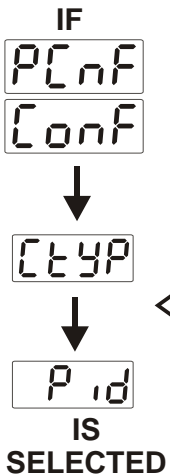
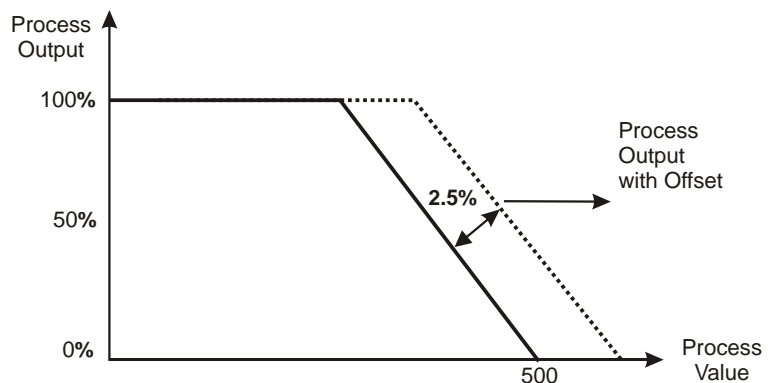

Strn

PROCESS VALUE STABILIZATION (1, SCALE HIGH POINT)

It is used for controlling if process value oscillates or not when tunn Parameter is Atun or AtSt

If;

$\text{PSEt} - \text{Strn} \leq \text{Process Value} \leq \text{PSEt} + \text{Strn}$ condition is not true and process value starts to oscillate (as shown in the diagram). If tunn parameter is Atun or AtSt , then AtEn parameter is selected YES and then Limit Cycle Tune operation starts for determining new PID parameters.

Scale High Point : Maximum process input value in Pt-100 and Tc inputs

9999 for fixed dual point calibration used inputs,

Scale high point is the biggest one from tPOL or tPOH for selectable dual point calibration used inputs

Scale high point is the biggest one from PO00 or PO16 for multi point calibration used inputs

Note: Point position changes according to process input type and scale, unit changes according to the selection in unit parameter.

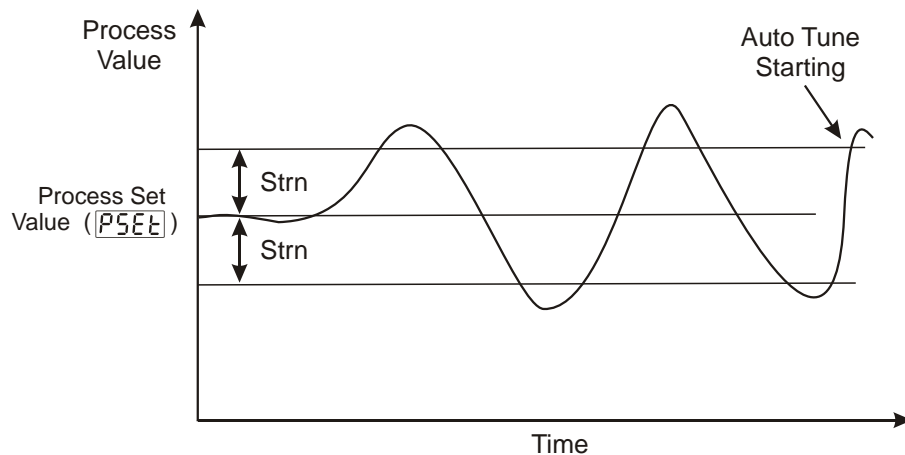
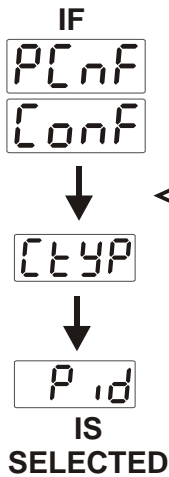

o-db

PROPORTIONAL BAND SHIFTING (- SCALE HIGH POINT / 2), (SCALE LOW POINT / 2))

If cooling function is performed ;

Cooling process set value is calculated by adding set value PSEt with parameter o-db

Control form can be ON/OFF or PID.

If set value for heating = $\text{PSEt} + \text{SUoF}$;

Then set value for cooling = $\text{PSEt} + \text{SUoF} + \text{o-db}$

Scale High Point : Maximum process input value in Pt-100 and Tc inputs

9999 for fixed dual point calibration used inputs,

Scale high point is the biggest one from tPOL or tPOH for selectable dual point calibration used inputs

Scale high point is the biggest one from PO00 or PO16 for multi point calibration used inputs

Note: Point position changes according to process input type and scale, unit changes according to the selection in unit parameter.

If $\boxed{a-db} > 0$

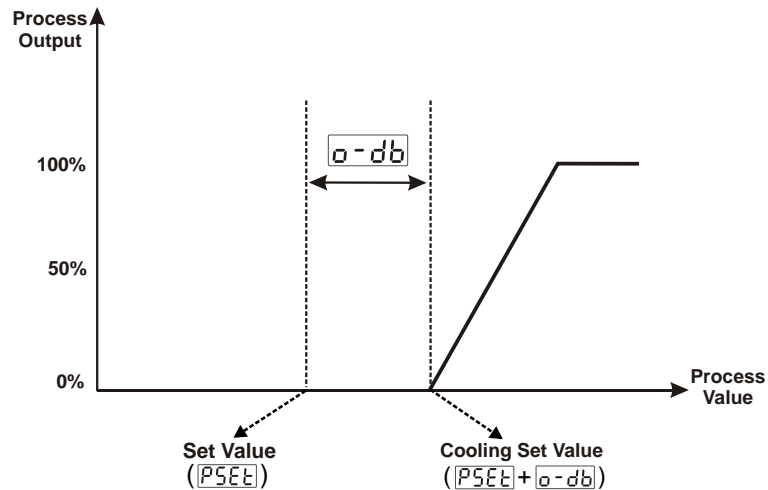

If $\boxed{a-db} < 0$

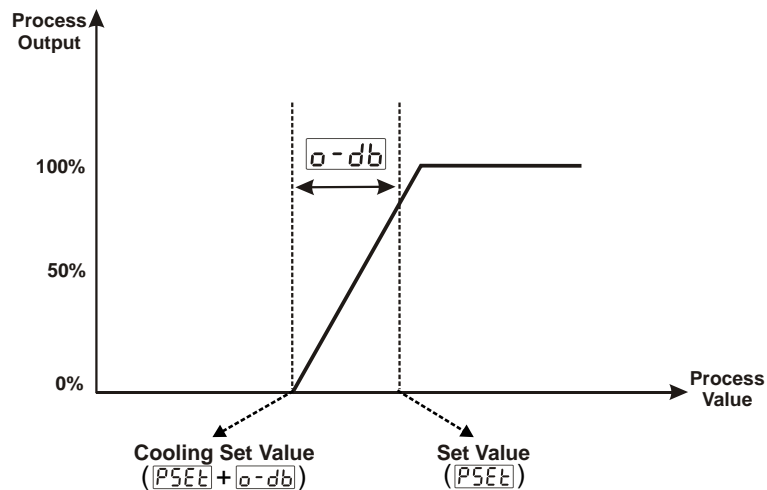

$\boxed{5b0u}$

**SENSOR BREAK OUTPUT VALUE
(FOR HEATING PID 0.0%, 100.0%)
(FOR COOLING PID -100.0%, 0.0%)**

When sensor breaks, controlling of the process can continue by entering %output value to $\boxed{5b0u}$ parameter. If this parameter 0.0, process control output does not perform an output when sensor breaks.

$\boxed{55Et}$

Soft Start Set value

It can be adjusted from 0 to 9999 with increment and decrement buttons. When the device power on, if the Soft start set value different from "0", and temperature value is lower than soft start value on heating processes, device starts soft start operation, until temperature reaches soft start set value. On soft start device output period is $\boxed{55Ct}$ parameter value and device control output is $\boxed{55Co}$ parameter value.

$\boxed{55Co}$

Soft Start Control Output

It can be adjusted from 10% to 90% with increment and decrement buttons.

$\boxed{55Ct}$

Soft Start Control Period

It can be adjusted from 0 to 100 sec with increment and decrement buttons.

PCnf

Conf

6.2.5 Process Output Configuration Parameters

oCnf

It determines if Process Output (SSR Driver Output) and Alarm Output-2 operates together or not.

0

Process Output (SSR Driver Output) and Alarm Output-2 operates separately.

1

Process Output (SSR Driver Output) and Alarm Output-2 operates together. Alarm functions of Alarm Output-2 can not be used

oFnC

It determines output functions of Process Outputs

HEAt

Heating

Cool

Cooling

CtYP

It determines control algorithms of Process Outputs

on.oF

ON/OFF control algorithm

P id

PID control algorithm

CtYP

on.oF

HYS

Hysteresis value of Process Outputs. It can be adjusted from 0% to 50% of full scale. (It is active if ON/OFF control is selected)

Hyn

It determines operation form of hysteresis (It is active if ON/OFF control is selected)

0

SV + HYS/2 and SV - HYS/2

1

SV and SV + HYS or SV and SV - HYS

offt

In ON/OFF operation, this time must be passed for the output to be energised again. It can be adjusted from 0.0 to 100.0 seconds. (It is active if ON/OFF control is selected)

6.2.6 ALARM Output-1 Configuration Parameters

Low1 It determines logic output function for Alarm Output-1

- 0 Alarm output
- 1 Manual / Automatic data output
- 2 Sensor break alarm output
- 3 Output is active when the process value is out of the band which is defined with minimum value of operating scale LoL and maximum value of operating scale uPL

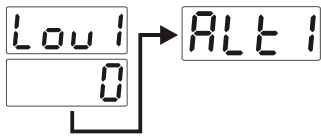

ALt1 It determines alarm type for Output-1. It is active if logic output function of Alarm Output-1 is alarm output.

- 0 Process high alarm
- 1 Process low alarm
- 2 Deviation high alarm
- 3 Deviation low alarm
- 4 Deviation band alarm
- 5 Deviation range alarm

Process high alarm

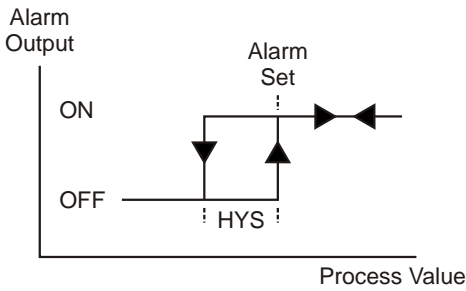

Process low alarm

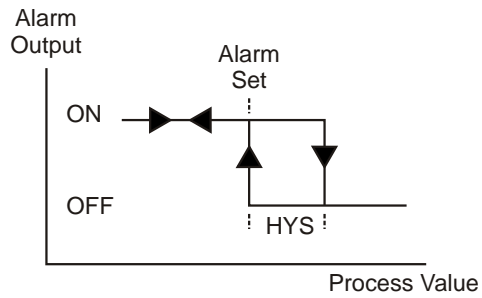

Deviation high alarm

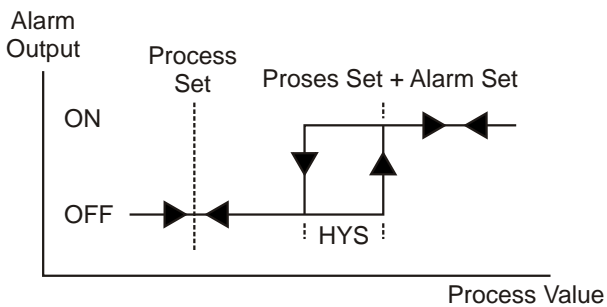

Deviation low alarm

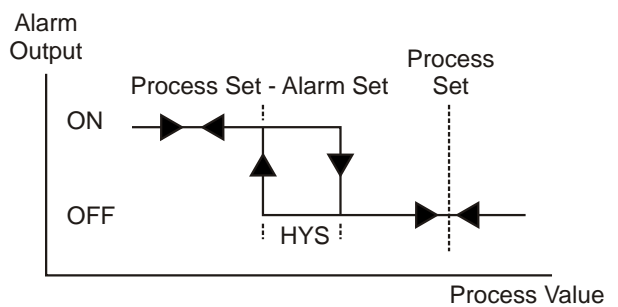

Deviation Band Alarm

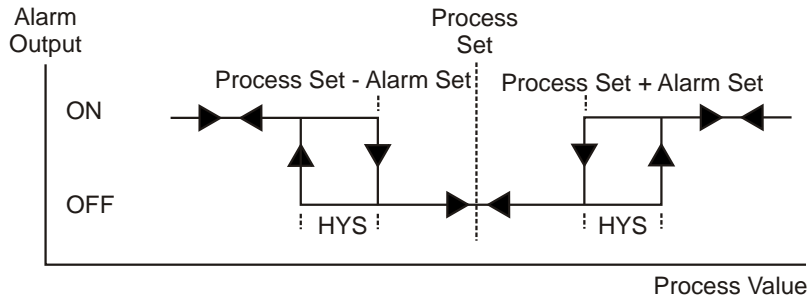

Deviation Range Alarm

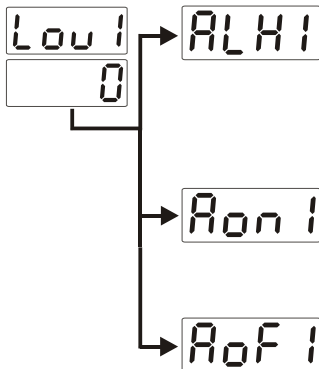
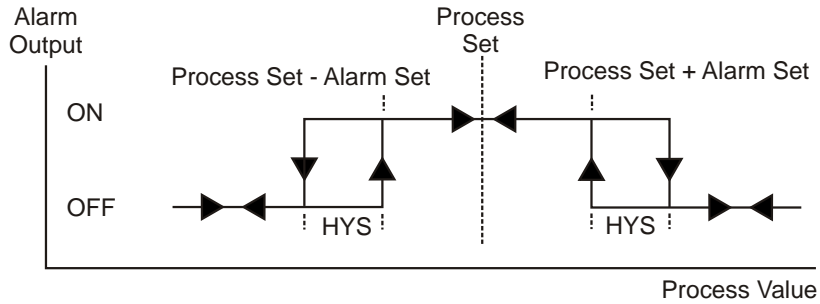

Alarm- 1 hysteresis value.

It can be adjusted from 0% to 50% of process input scale ($\text{uPL} - \text{LoL}$). It is active if logic output function of Alarm Output-1 is alarm output.

Alarm on delay time for Alarm Output-1. It can be adjusted from 0 to 9999 seconds. It is active if logic output function of Alarm Output-1 is alarm output.

Alarm off delay time for Alarm Output-1. It can be adjusted from 0 to 9998 seconds. When the value is greater than 9998, **LECH** is seen on the screen. It means alarm latching output is selected. It is active if logic output function of Alarm Output-1 is alarm output.

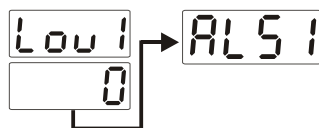
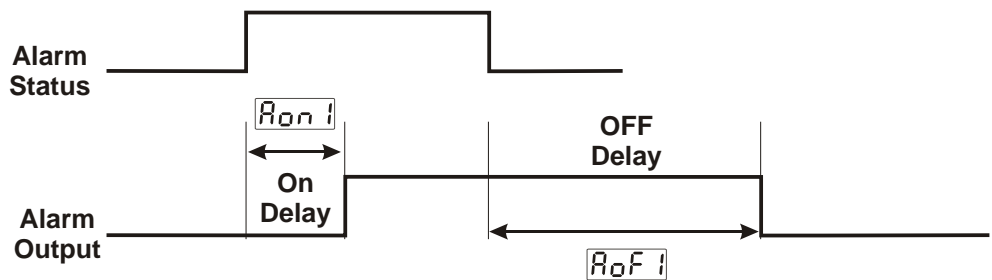

Alarm stabilisation time for Alarm Output-1. It can be adjusted from 0 to 99 second. It is active if logic output function of Alarm Output-1 is alarm output. After the unit is power-on and Alarm Stabilisation Time is expired, if an alarm condition which is selected with Alt1 is present, then Alarm output-1 becomes active.

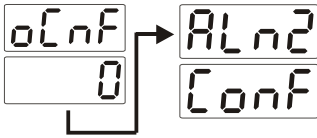

6.2.7 ALARM Output-2 Configuration Parameters



“Aln2 Conf” Menu is accessible if parameter in “PCnF Conf” is

It determines logic output function for Alarm Output-2

- Alarm output
- Manual / Automatic data output
- Sensor break alarm output
- Output is active when the process value is out of the band which is defined with minimum value of operating scale and maximum value of operating scale

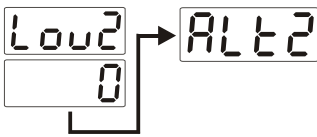

It determines alarm type for Output-2. It is active if logic output function of Alarm Output-2 is alarm output.

- Process high alarm
- Process low alarm
- Deviation high alarm
- Deviation low alarm
- Deviation band alarm
- Deviation range alarm

Process high alarm

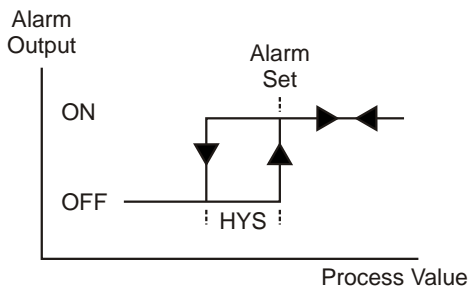

Process low alarm

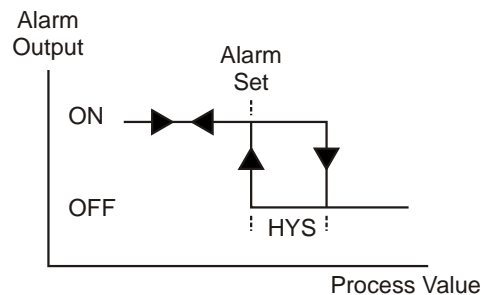

Deviation high alarm

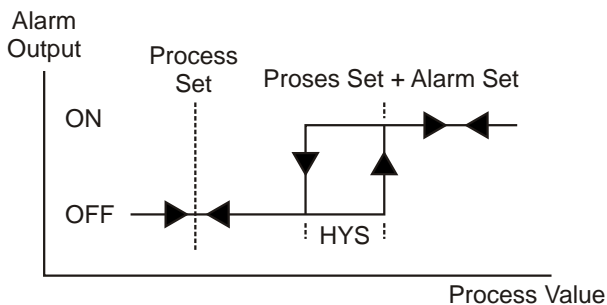

Deviation low alarm

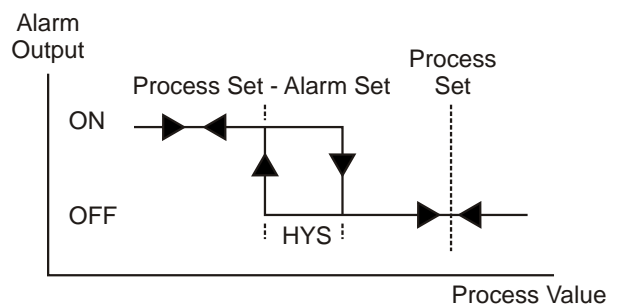

Deviation band alarm

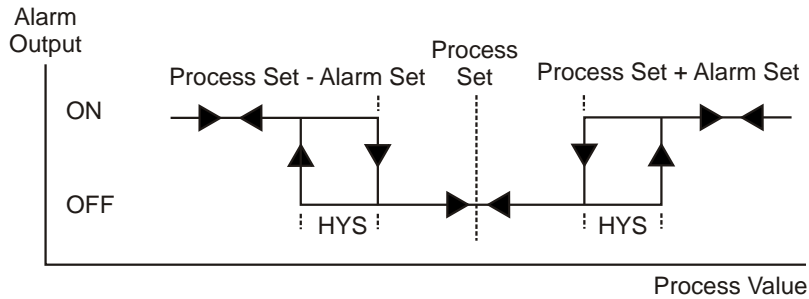

Deviation range alarm

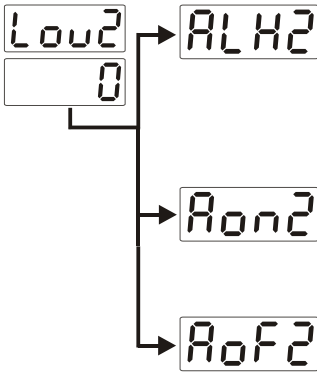
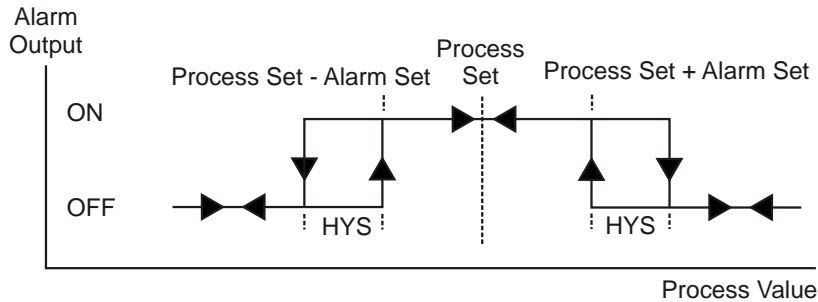

Alarm- 2 hysteresis value.

it can be adjusted from 0% to 50% of process input scale
($\text{uPL} - \text{LoL}$) It is active if logic output function of Alarm Output-2 is alarm output.

Alarm on delay time for Alarm Output-2. It can be adjusted from 0 to 9999 seconds. It is active if logic output function of Alarm Output-2 is alarm output.

Alarm off delay time for Alarm Output-2. It can be adjusted from 0 to 9998 seconds. When the value is greater than 9998, **LECH** is seen on the screen. It means alarm latching output is selected. It is active if logic output function of Alarm Output-2 is alarm output.

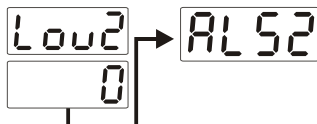
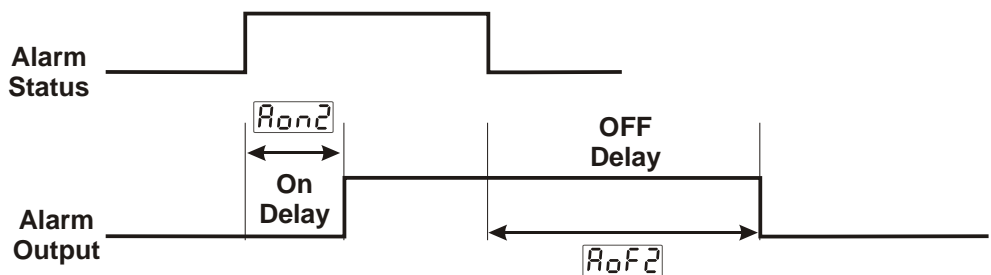

Alarm stabilisation time for Alarm Output-2. It can be adjusted from 0 to 99 second. It is active if logic output function of Alarm Output-2 is alarm output. After the unit is power-on and Alarm Stabilisation Time is expired, if an alarm condition which is selected with Alt2 is present, then Alarm output-2 becomes active.



“Aln2 Conf” Menu is accessible if **oLnF** parameter in “PCnF Conf” is

6.2.8 General Parameters

SU-L Minimum value for process set and alarm set values. It is named as low limit of set scale.

It can be adjusted from low limit of input selected with **ISSL** parameter to **SU-U** parameter.

Please refer to Section 6.2.3 Process Input Type and Relevant Parameters with Process Input for **ISSL** parameter

SU-U Maximum value for process set and alarm set values. It is named as high limit of set scale.

It can be adjusted from **SU-L** to high limit of input selected with **ISSL** Parameter.

Please refer to Section 6.2.3 Process Input Type and Relevant Parameters with Process Input for **ISSL** parameter

Pr1 **Alarm Set Values Protection**

no Alarm Set values can be changed

YES Alarm Set values can not be changed. Alarm set values parameters, **ALr1** and **ALr2** , are not accessible

Pr2 **AUTO / MANUAL Selection Button Protection**

no Auto or Manual selection is possible with A/M button in Main Operation screen

YES Auto or Manual selection is not possible with A/M button in Main Operation screen

Pr3 **AT (AUTO TUNE) Button Protection**

no Limit Cycle Tuning operation can be active or inactive with AT (Auto Tune) Button in Main Operation screen

YES Limit Cycle Tuning operation can not be active or inactive with AT (Auto Tune) Button in Main Operation screen

PASS

Conf

6.2.9 Technician Password

ECPS

It is used for accessing to the technician parameters.
It can be adjusted from 0 to 9999.

If it is ; there is no password protection while entering to the technician parameters.

If it is different from “ 0” and user wants to access to the technician parameters;

1- If technician does not enter password correctly:

It turns to operation screen without entering to operator parameters.

2- When in top display and in bottom display, if technician presses SET button without entering password (For observing parameter)

Technician can see all menus and parameters except Technician Password menu (“Pass Conf”), but parameters can not be changed.

(Please refer to Section 7. Failure Messages (4) in ESM-4430 Process Controllers)

7. Failure Messages in ESM-4430 Process Controllers



1 - Sensor failure in analogue inputs. Sensor connection is wrong or there is no sensor connection.

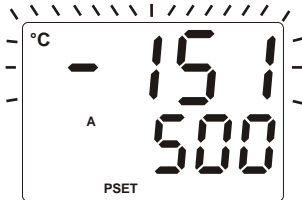

2 - If value on top display blinks : If analogue input value is less than minimum value of operating scale **LoL** value on the top display starts to blink.

In "PynP Conf" Menu if;

SSL 0 ; **ECSL** 2 ; **unit** °C ;
LoL -200 ; **uPL** 900 are defined.

Adjust **LoL** -150

If analogue input value is less than minimum value of operating scale **LoL** Value on the top display starts to blink.



Please refer to Section 6.2.3 for detailed information about this parameter.



3 - If value on top display blinks : If analogue input value is greater than maximum value of operating scale **uPL** top display starts to blink.

In "PynP Conf" Menu if;

SSL 0 ; **ECSL** 2 ; **unit** °C ;
LoL -200 ; **uPL** 900 are defined.

Adjust **uPL** 850

If analogue input value is greater than maximum value of operating scale **uPL** value on the top display starts to blink.



Please refer to Section 6.2.3 for detailed information about this parameter.

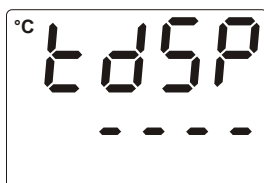

4 - If technician password is different from "0" and technician accesses to the parameters by Set button without entering the technician password and wants to change a parameter, device does not allow to do any changes in parameters. If increment or decrement button is pressed, a warning message will appear on the bottom display as shown on the left.

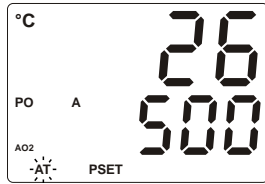

5 - If tuning operation can not be completed in 8 hours, AT led starts to blink. Blinking can be canceled by pressing Enter button.



For details on parameters, refer to Section 6.2.1



6 - If user does not do anything for 120 seconds while device is on technician menus, device turns to operation screen.



8. Specifications

Device Type	: Process Controller
Housing&Mounting	: 48mm x 48mm x 87.5mm 1/16 DIN 43700 plastic housing for panel mounting. Panel cut-out is 46x46mm.
Protection Class	: NEMA 4X (IP65 at front, IP20 at rear).
Weight	: Approximately 0.15 Kg.
Environmental Ratings	: Standard, indoor at an altitude of less than 2000 meters with none condensing humidity.
Storage/Operating Temperature	: -40 °C to +85 °C / 0 °C to +50 °C
Storage/Operating Humidity	: 90 % max. (None condensing)
Installation	: Fixed installation
Over Voltage Category	: II
Pollution Degree	: II, office or workplace, none conductive pollution
Operating Conditions	: Continuous
Supply Voltage and Power	: 100 - 240 V \sim (-15% / +10%) 50/60 Hz 6VA 24 V \sim (-15% / +10%) 50/60 Hz 6VA 24 V \equiv (-15% / +10%) 6W
Process Inputs	: Universal input TC, RTD, \equiv Voltage/Current
Thermocouple Input Types	: Selectable by parameters L (DIN43710) , J , K , R , S , T , B , E , N (IEC584.1)(ITS90) , C (ITS90)
Thermoresistance Input Types	: PT 100 (IEC751) (ITS90)
\equiv Voltage Input Types	: Selectable by parameters 0..50mV \equiv , 0..5V \equiv , 0..10V \equiv
\equiv Current Input Types	: Selectable by parameters 0...20mA \equiv , 4...20mA \equiv

Accuracy	: $\pm 0,25\%$ of full scale for thermocouple, thermoresistance and --- voltage, $\pm 0,70\%$ of full scale for current.
Cold Junction Compensation	: Automatically $\pm 0.1^{\circ}\text{C}/1^{\circ}\text{C}$.
Line Compensation	: Maximum 10 .
Sensor Break Protection	: Upscale
Sampling Cycle	: 3 samples per second
Input Filter	: 0.0 to 900.0 seconds
Control Forms	: Programmable ON / OFF, P, PI, PD or PID.
Relay Outputs	: 2 pieces 5A@250V \sim (at resistive load) (Programmable control or alarm output) (Electrical Life :100000 operation (Full Load))
Standard SSR Driver Output	: Max. 17mA, Max. 25V ---
Process Display	: 10.1 mm Red 4 digits LED display
Set Display	: 8 mm Green 4 digits LED display
LED Indicators	: AT (Auto Tune), M (Manual Mode), A (Automatic Mode), PSET (Process Set Value), ASET1 (Alarm-1 Set Value), ASET2 (Alarm-2 Set Value), PO (Process Output) , AO1 (Alarm Output-1), AO2 (Alarm Output-2) $^{\circ}\text{C} / ^{\circ}\text{F} / \text{V}$ Unit leds
Approvals	: UL Recognized Component (File No : E 254103), GOST-R, CE

9. Other Informations